

User Manual and Parts Book



GF-1130-448 MH/L34

ANITA B s.r.o.

Průmyslová 2453/7

680 01 Boskovice

Czech republic

tel: +420 516 454 774

+420 516 453 496

fax: +420 516 452 751

e-mail: info@anita.cz

All rights reserved. Property of Anita B s.r.o. and protected by copyright.
The use of this content without written consent of Anita B s.r.o. is prohibited.
Copyright © Anita B s.r.o. (2020)

Content

A	Basic Information	6
	A1. Product description and intended use.....	6
	A2. Technical specifications	6
B	Safety Instructions	7
	B1. General instructions.....	7
	B2. Installation precautions.....	7
	B3. Operational safety instructions.....	8
	B4. Working safety instructions	8
	B5. Disposal instructions	9
C	Machine Setup	10
	C1. Oil sump installation.....	10
D	Operating Instructions	11
	D1. Replacing the needle	11
	D2. Threading the machine	12
	D2.1. Threading the bottom thread.....	12
	D2.2. Winding the bobbin	13
	D2.3. Threading the upper thread	14
	D3. Adjusting the stitch length and reverse stitch.....	15
	D4. Thread tension adjustment.....	16
	D4.1. Upper thread tension adjustment.....	16
	D4.2. Bottom thread tension adjustment.....	16
	D5. Presser foot.....	17
	D5.1. Presser foot lift	17
	D5.2. Foot pressure adjustment.....	17
	D6. Hook safety clutch function	18
	D7. Timing of the hook opener	18
	D8. Timing of the hook and the needle.....	19
	D9. Control buttons.....	21
	D10. Turning the LED light on/off	21
E	Machine Maintenance	22
	E1. Lubricating the machine.....	22
	E1.1. Lubricating the front part of the machine head	22
	E1.2. Lubricating the machine head.....	22
	E1.3. Refilling the oil sump.....	23
	E2. Adjusting the lubrication	24

E2.1. Adjusting the lubrication of the hook	24
E2.2. Adjusting the lubrication of the upper oil tank.....	24
F Troubleshooting	25
G Drive Unit Manual	26
G1. Safety instructions	26
G2. Description and intended use of a drive unit	26
G3. Drive unit technical parameters	26
G4. Installation and adjustment.....	27
G4.1. Dimension of control box and speed controller bracket (direct driven).....	27
G4.2. Speed controller	27
G4.3. Installation diagram of system	27
G5. electrical connection.....	28
G5.1. Connecting the power supply	28
G5.2. Single phase 230V power connection	28
G5.3. Three phase 380V power connection.....	28
G6. connector diagram.....	29
G7. operating field p200b	31
G8. get started with your machine	32
G8.1. Machine ID.....	32
G8.2. Adjust the ZERO of the machine.....	33
G9. operating elements.....	33
G9.1. Single start back-tacking setting.....	33
G9.2. Double start back-tacking setting.....	33
G9.3. Single end back-tacking setting	33
G9.4. Double end back-tacking setting	33
G9.5. Lower thread counter	33
G9.6. Product quantity counter	34
G9.7. Adjust the backtack	34
G9.8. Other adjustment	34
G10. operating of the special function interface	35
G11. parameter instruction.....	35
G11.1. Setting parameter.....	35
G11.2. Get the permission of setting 0 type parameter	36
G11.3. Parameter solidifying.....	36
G11.4. Other Parameter adjustment	36
G11.5. General parameter table	37
G12. Error Message, possible troubleshooting.....	41

G13. Controller check.....	41
G14. Appendix.....	43
H Spare parts book	44
H1. Frame & covers	44
H2. Take-up and upper shaft components	46
H3. Needle bar rocking.....	48
H4. Pressure adjusting & upper feed mechanism (1/2).....	50
H5. Pressure adjusting & upper feed mechanism (2/2).....	52
H6. Feed mechanism (1/2)	54
H7. Feed mechanism (2/2)	56
H8. Hook shaft & upper feed mechanism	58
H9. Thread cutting components.....	60
H10. Thread tension components.....	62
H11. Lower thread winder mechanism components.....	64
H12. Lubrication components (1/2)	66
H13. Lubrication components (2/2)	68
H14. Automatic presser lifting mechanism	70
H15. Thread stand components	72
H16. Automatic back-tack components	74
H17. DI-mechanism components	76
H18. Air mechanism components	78

A BASIC INFORMATION

A1. PRODUCT DESCRIPTION AND INTENDED USE

The machine is designated for use in the apparel, home textiles, accessories and footwear production. It is suitable for making car seat covers, sofas, leather bags, tents, etc. Triple synchronous feed and special feeder provide smooth operation and even stitch even for heavy materials. Characteristic features of this machine are low level of noise and vibrations and large-capacity hook.

A2. TECHNICAL SPECIFICATIONS

Model	GF-1130-448 MH/L34
Number of needles	1
Needle gauge	-
Use	Medium/Heavy materials
Stitch type	2-thread lockstitch
Max. stitch length	max. 9 mm
Hand lever foot lift	9 mm
Knee lever foot lift	19 mm
Needle system	135x17 for fabrics, 135x16 for leather
Needle size	Nm. 110 -180 *
Hook type	Vertical with \varnothing 26 mm bobbin
Lubrication	Automatic with oil pump
Motor	Integrated servomotor 1x230V
Machine head weight	66 kg
Table weight	27 kg
Working space	340 x 125 mm
Machine table dimensions	595 x 190 mm
Power	max. 850 W (for a short time during start-up)
Ground plan dimensions (including frame)	1200 x 550 mm
Bedplate height	740 – 800 mm
Machine height including thread stand	1550 mm
Noise level under standard conditions	82 dB/A
Max. sewing speed	3000 st./min. **

* Machine is preset for needle Nm. 160

** Do not exceed specified sewing speed due to the service life of the machine mechanism. This cannot be guaranteed under any conditions. It is necessary to reduce speed depending on the thread, needle and material, stitch length and the foot track.

B SAFETY INSTRUCTIONS

Read the instructions carefully before installation and use. Keep this manual for future reference.

B1. GENERAL INSTRUCTIONS

1. Do not operate the sewing machine until proper preparation has been made by a technician or qualified person and safety precautions have been taken.
2. Always follow the safety instructions when handling the machine.
3. This sewing machine may only be operated by properly trained personnel.
4. Maintenance, repair, inspection and adjustment of the machine may only be carried out by a qualified person.
5. Work on electrical equipment may only be performed by a qualified worker or person with the appropriate authorization. Work on electric parts and equipment on your own is not permitted.
6. The machine may only be used for its intended purpose.
7. The warranty does not cover any problems in the operation of the machine that are caused by unauthorized modifications to the machine, as well as problems caused by non-observance of the instructions given in this manual and generally known habits for the operation and maintenance of industrial sewing machines.

B2. INSTALLATION PRECAUTIONS

1. Immediately report visible damage to the carrier. Check the contents of the order shipment and report any defects immediately to the manufacturer. Later claims will not be accepted.
2. Use the machine after checking that it meets all the safety standards of your country.
3. The machine head is covered with a corrosion-proof coating. Wipe off the lubrication and dust layer with a cloth or petrol before placing it on the work surface.
4. The machine has been thoroughly inspected and tested before shipment. However, it may have been damaged by transport or impact. Check the operation of the machine with the handwheel, to detect extraordinary noises, heavy running, etc. before starting the test sewing.
5. Never start the machine if the oil level is under or over the marked lines.
6. Check that the power and phase are in accordance with the label instructions.
7. Proper grounding of the machine is necessary.
8. Use the correct grounding plug.
9. Do not use an extension cord.
10. Make sure that the power supply and voltage match the requirements on the label of the machine.
11. Do not use the machine in explosive or corrosive environment.
12. In the first two weeks, do not exceed 3/4 of the maximum machine speed.
13. Check that the air pressure is between 0.55 and 0.6 MPa.

B3. OPERATIONAL SAFETY INSTRUCTIONS

1. Do not use the machine without a belt cover, finger guards or other protective equipment.
2. All protective equipment of the machine must be in place before operation. Do not use the machine without covers and protective equipment.
3. Repair damaged covers or replace them immediately.
4. If the safety label is damaged, order a new one from the machine supplier and place it in its original position.
5. Switch off the machine and unplug it in these situations (the motor still rotates after turning off; wait until it stops completely):
 - when threading the needle (needles), hooks, etc.
 - when changing the needle, presser foot, needle plate, hooks, hook bobbins, feeders, needle guards, finger guards, work guides, etc.
 - when the machine is not in use and left unattended
 - when opening or removing the protective covers
 - for any maintenance, repair, inspection and adjustment of the machine
 - when cleaning the machine
6. Wear safety goggles and gloves when lubricating the machine. Do not drink oil under any circumstances, as it may cause vomiting and diarrhoea. Keep oil out of the reach of children.
7. Take special care when lifting / tilting the machine head. When tilting the machine head, make sure the machine is turned off. Always hold the machine head with both hands.
8. When handling cords and plugs, check if the machine is switched off to avoid electrical shock and injury.
9. Check the electrical cords for damage to avoid injury by touching an exposed wire.
10. Do not place any objects on the power cord.
11. Do not open or touch the inside of the junction box.
12. It is strictly forbidden to connect any connector while the machine is powered. Risk of damage to electrical components and drives.
13. Do not modify the machine in any way that could endanger safety.
14. Clean the machine regularly during operation.
15. Do not wipe the machine with thinner or acetone.
16. Use only original or approved spare parts from manufacturer.
17. Ensure adequate illumination of the work area and the surroundings of the machine.
18. Disconnect the compressed air supply before servicing and repairing pneumatic equipment. Drain off the residual compressed air before servicing.

B4. WORKING SAFETY INSTRUCTIONS

1. Make sure you know the position of Stop button before starting to work.
2. Do not touch any moving parts or put objects into the machine while sewing.
3. Be careful not to catch or place objects near the machine's moving mechanisms, particularly fingers, sleeves, clothing and hair.
4. Never touch the needle when the machine is turned on and sewing.
5. Never reach under the thread lever cover while the machine is on.
6. Do not place your fingers in the needle guard holder when feeding material manually.

7. Do not work on the machine under the influence of alcohol or drugs.
8. We recommend wearing safety goggles.
9. Do not remove covers or any other safety device while the machine is running.
10. Always turn off the main switch when leaving the machine.

B5. DISPOSAL INSTRUCTIONS

For disposal of the machine contact your local dealer or manufacturer in accordance with legislation.

C MACHINE SETUP

C1. OIL SUMP INSTALLATION

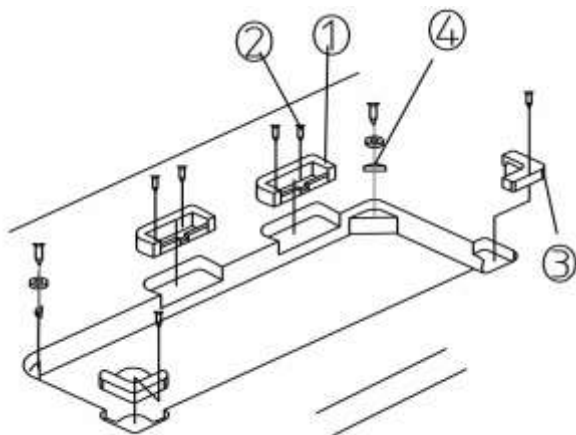

Insert rubber cushions ①, ③, ④ into the bedplate and tighten the screws ②.

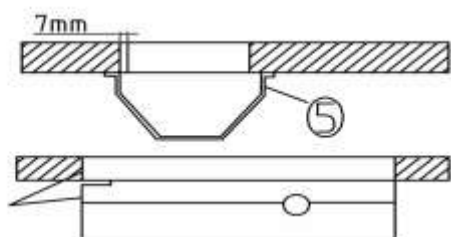

Installation of the oil sump:
According to the picture fasten the oil sump (5) to the plate with eight screws.

D OPERATING INSTRUCTIONS

D1. REPLACING THE NEEDLE

Turn off the main power switch. Replace the needle only when the sewing machine is off.

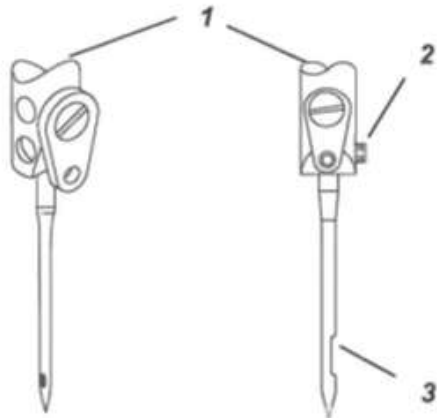

Turn the hand wheel to rise the needle bar 1 to the highest position.

Loosen the screw 2.

Pull out the needle from the needle bar 1 downwards.

Insert new needle into the opening in the needle bar 1 all the way up with the groove 3 to the right.

Tighten the screw 2.

When changing the needle size, you must adjust the distance of the hook to the needles, otherwise it will lead to malfunctioning:

Using the smaller size of the needle:

- Skipping the stitches
- Damaging the thread

Using the larger size of the needle:

- Damaging of the tip of the hook
- Damaging the needle

D2. THREADING THE MACHINE

D2.1. Threading the bottom thread

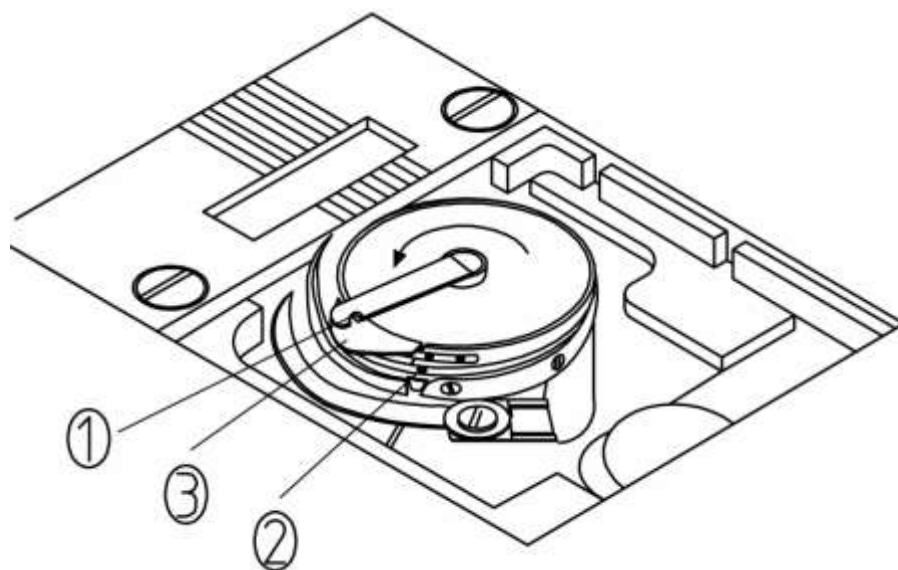

1. Pull the latch up ①.
2. Hold the bobbin with the loose end of the thread in a CCW direction and put it into the hook.
3. Pass the thread through the opening ② and ③ and under the bottom thread tension spring.
4. Pull the thread out, the bobbin must turn in a CCW direction.

D2.2. Winding the bobbin

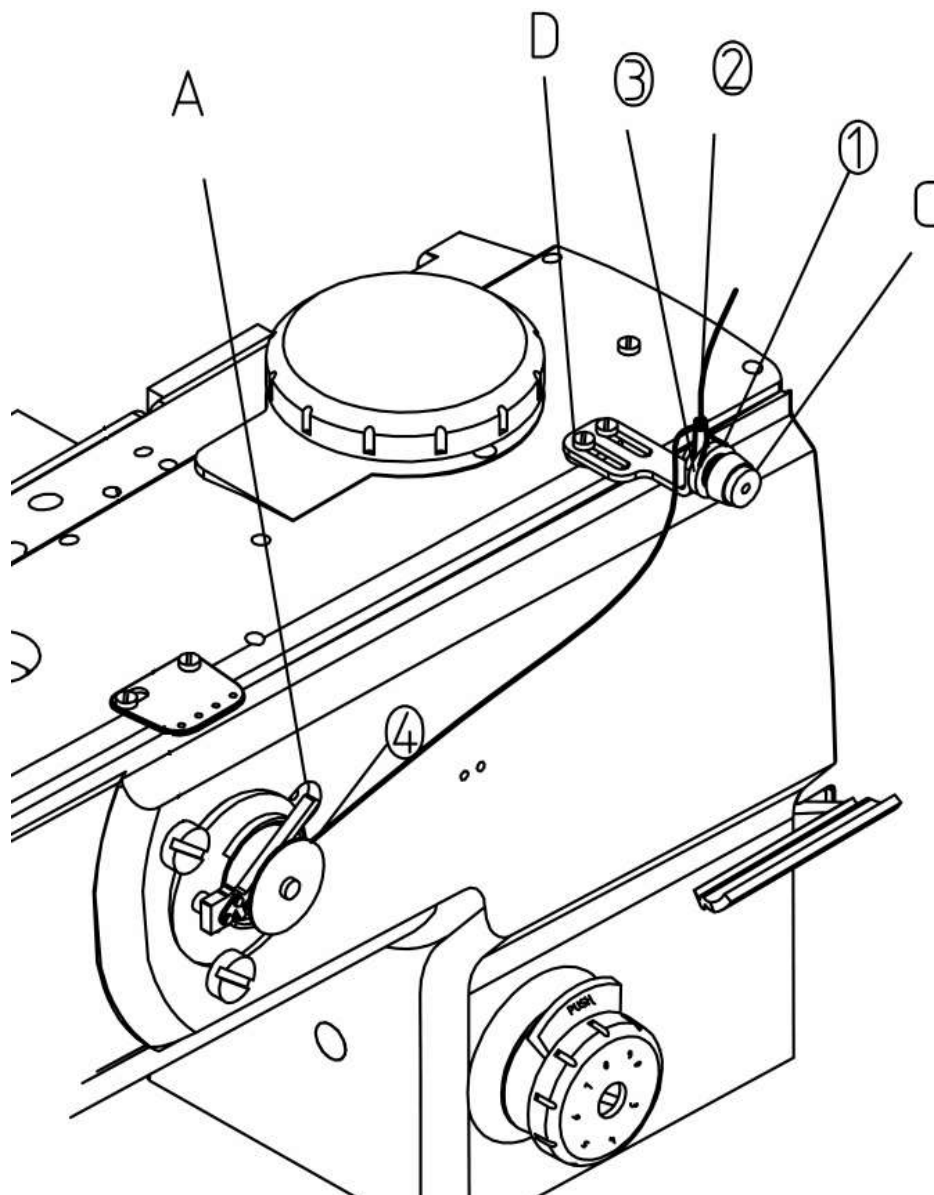

1. Put the bobbin on the winding pin. Pass the thread through points ① to ③ and wind the end of the thread a few times around the bobbin.

2. Press the winder lever ④. Press the foot controller and machine will start winding. When the bobbin is full, winding stops automatically.

3. You can adjust the amount of thread by the metal plate screwed on to the winder lever A. Loosen the screw and adjust position of the plate to stop winding at 80 % of the bobbin capacity.

4. It's necessary to wind the thread evenly. Center the thread tension ③, adjust the position forward / backward and tighten the screw ④.

D2.3. Threading the upper thread

1. Thread the upper (needle) thread of GF-1130-448 MH as shown in the picture.

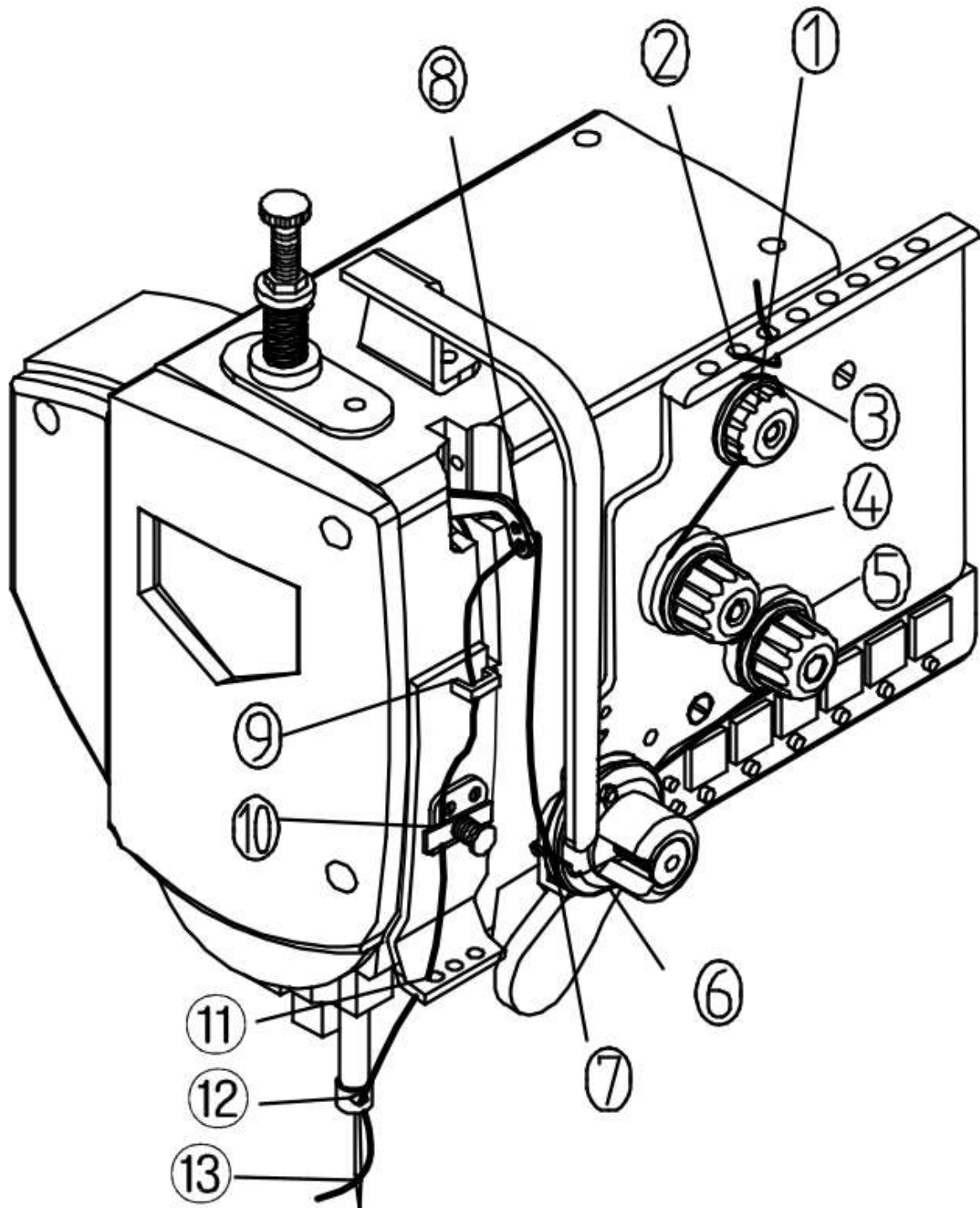

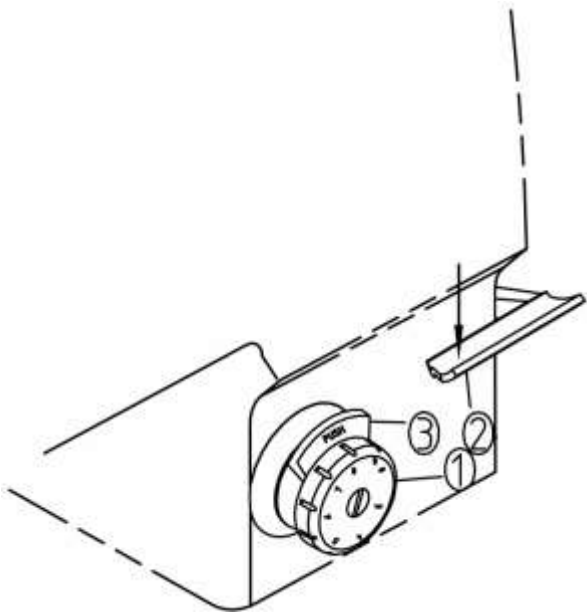

D3. ADJUSTING THE STITCH LENGTH AND REVERSE STITCH

1. Press the locking plate ③ and set the desired stitch length by turning the dial ①.

2. Press the reverse lever ②, the machine will sew back. When the lever is released, the machine sews forward again.

D4. THREAD TENSION ADJUSTMENT

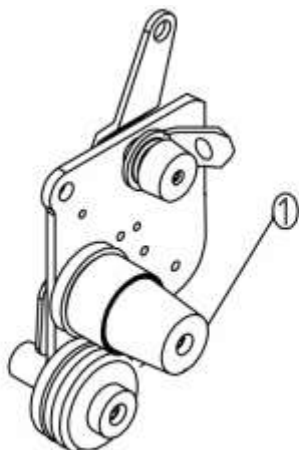

D4.1. Upper thread tension adjustment

Turn the thread tension nut ① clockwise to increase the tension. Turn the nut counterclockwise to decrease the tension. In double-needle machines, each thread has its own tension wheel.

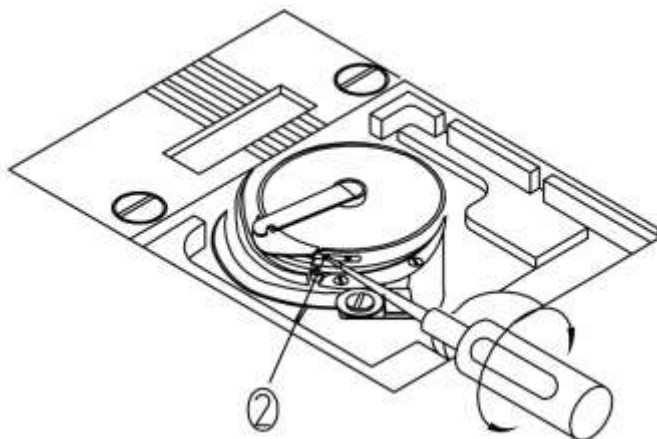

D4.2. Bottom thread tension adjustment

Turn the tension screw ② clockwise to increase the tension. Turn the screw counterclockwise to decrease the tension.

D5. PRESSER FOOT

D5.1. Presser foot lift

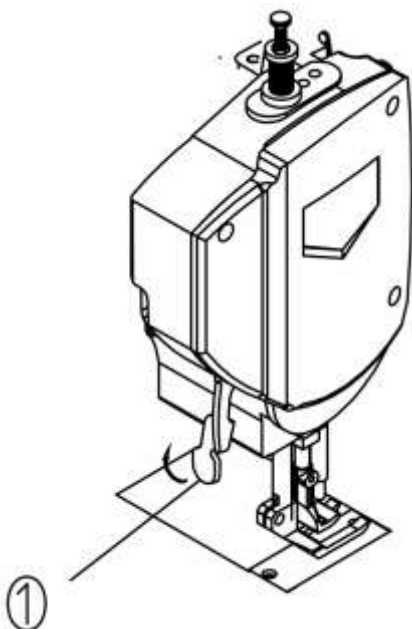

1. Raise the presser foot lever (1) up to a height of 9 mm.
2. Lowering the lift lever will lower the foot.
3. You can also lift the presser foot up to 19 mm using the knee lever or by pressing the pedal backwards. Pressing the pedal backwards requires a pressurized air supply.

D5.2. Foot pressure adjustment

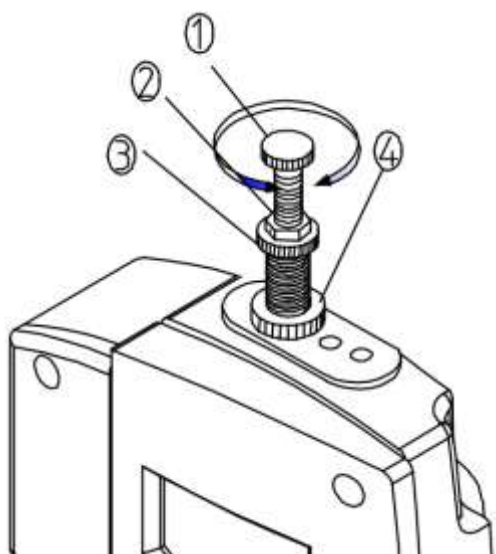

The nut (4) is used to lock the screw (3). Loosen it before adjusting the pressure and tighten again after adjustment.

Turn the foot pressure screw (3) clockwise to increase the foot pressure. Turn it counterclockwise to decrease the pressure.

Similarly, use the screw (1) and nut (2) to fine-tune the foot pressure.

D6. HOOK SAFETY CLUTCH FUNCTION

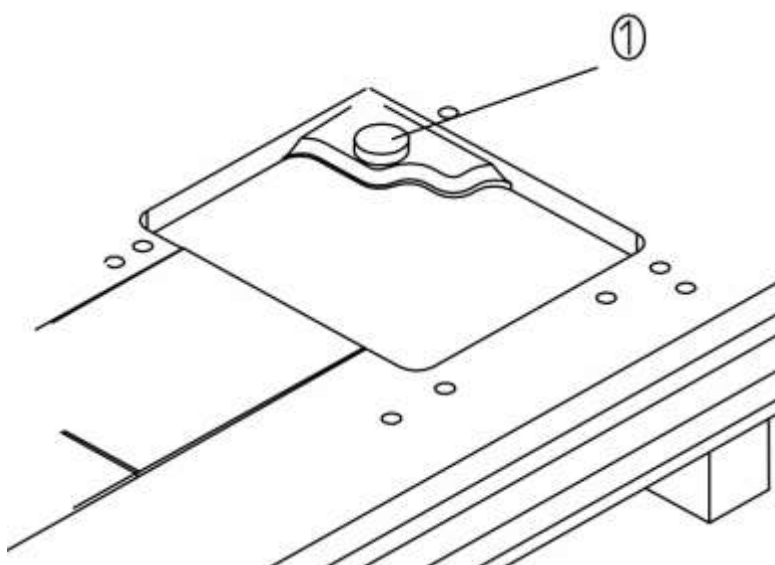

During sewing, when the hook reaches beyond the limit, a safety lock is activated to lock it. The needle will be still moving, but not the hook. Always remove the cause before running.

1. Press the button ① and turn the handwheel (CCW) until button ① clicks. Keep the button pressed and turn the handwheel backward (CW), until you hear a click.
2. Before running the machine motor in the usual way, check the proper functioning by turning the handwheel manually.

D7. TIMING OF THE HOOK OPENER

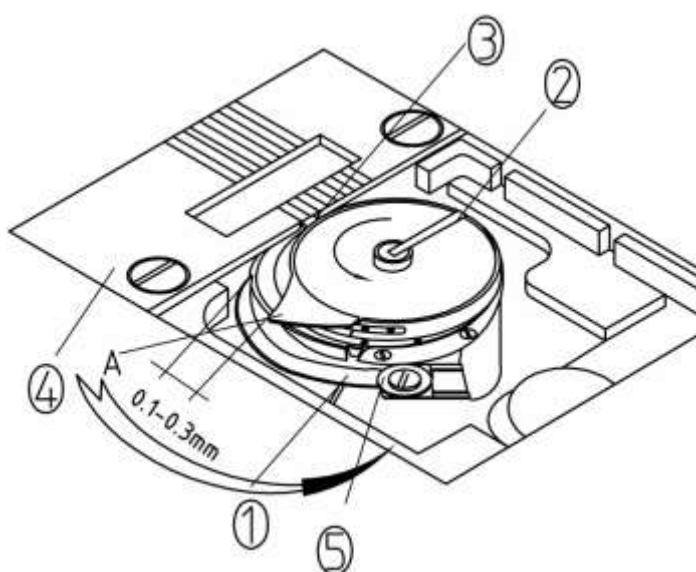

1. Turn the handwheel until hook opener ① moves to the far right.
2. Push the hook ② in the direction of the arrow to bring it as close as possible to the hook opener ① until the nose ③ touches the groove on the needle plate ④.
3. Loosen the screw ⑤ and set the distance between the hook opener ① and the hook inner part A to 0.1-0.3 mm.

D8. TIMING OF THE HOOK AND THE NEEDLE

Make the settings below with the stitch length set to 0.

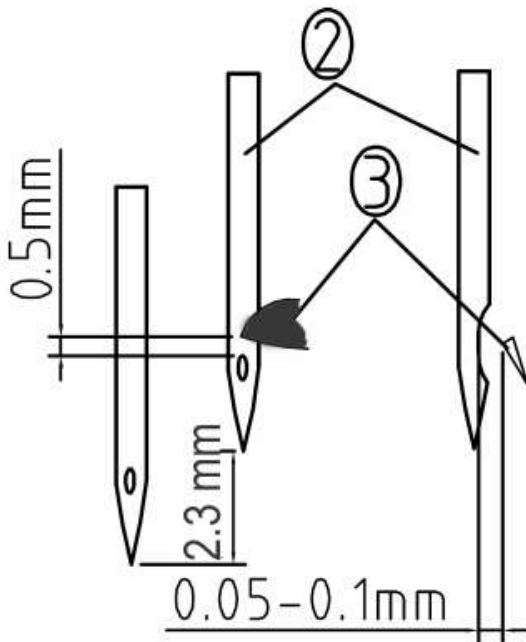

1. Turn the handwheel and raise the needle bar 2.3 mm from the lowest position. Check if the needle ② and the tip of the hook ③ align with each other. If not, loosen the two screws ④ of the small gear and rotate the hook to bring its tip to the center of the needle. We call this position "the machine at the set point of 2.3 mm."

2. Adjust the height of the needle bar to the point when "the machine is at the set point of 2.3 mm", the hook tip is about 0.5 mm above the upper edge of the needle eye. Loosen the needle bar screw ① and adjust the distance between the upper edge of the needle eye ② and the hook tip ③ to 0.5 mm. Tighten the screw.

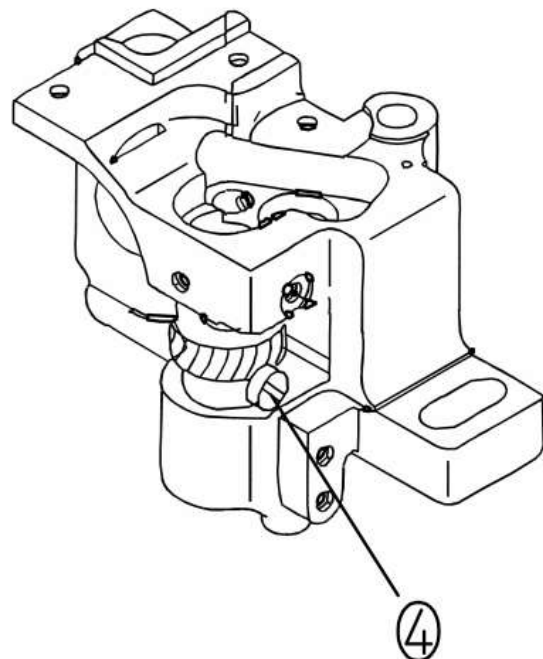
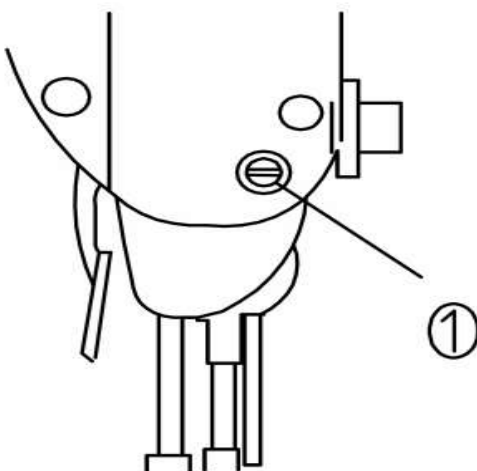

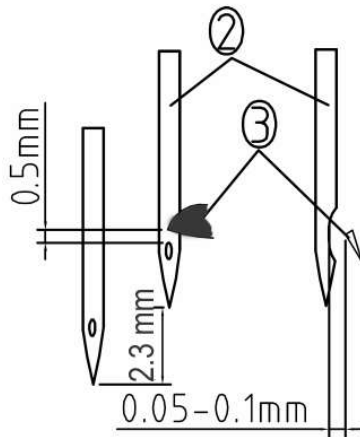

3. To adjust the distance between the hook tip (3) and the needle (2), loosen the hook block screws (6) and the gear screws (5). Adjust the distance to 0.05-0.1 mm. Then tighten all screws.

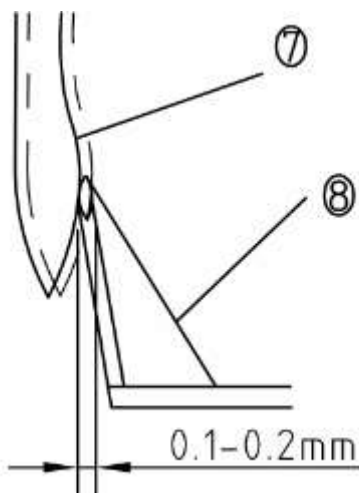
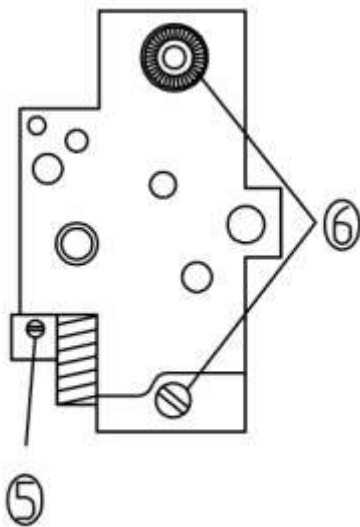

4. Adjust the guard plate of the hook by bending it so that the distance between the plate (8) and the needle (7) is 0.1-0.2 mm. The guard plate is intended to prevent contact of the needle with the hook tip, if the needle bends.

Adjust the distance when changing the needle size.

D9. CONTROL BUTTONS

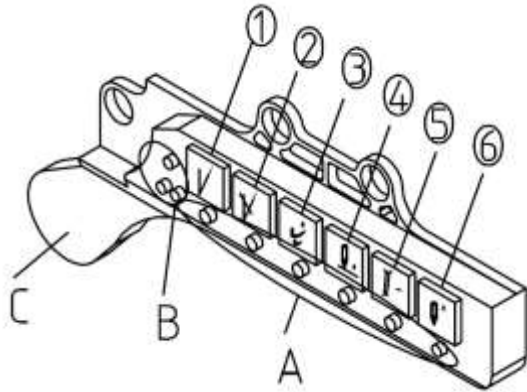

Use the control buttons 1 to 6 to quickly switch on/off the desired function:

1. Reverse sewing
2. Cancelling the start/end back-tack
3. Presser foot pre-lift
4. Move the needle by $\frac{1}{2}$ turn
5. Auxiliary tension
6. Pneumatic presser foot guide

Button "C" can be programmed for one of the functions by holding down button "A" under the chosen button 1 to 6 until LED "B" flashes. You can manage chosen function by pushing the "C" button.

D10. TURNING THE LED LIGHT ON/OFF

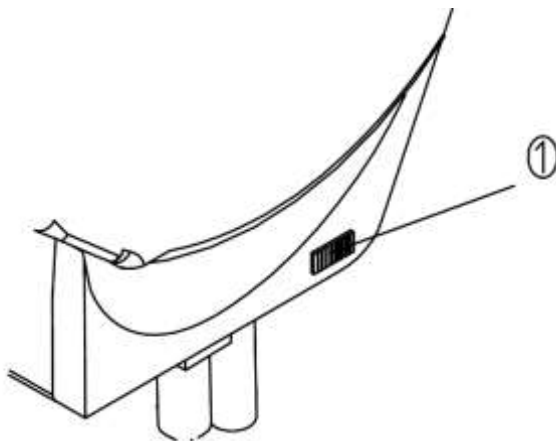

Turn the lighting on/off using switch 1 on the side of the lighting.

E MACHINE MAINTENANCE

E1. LUBRICATING THE MACHINE

E1.1. Lubricating the front part of the machine head

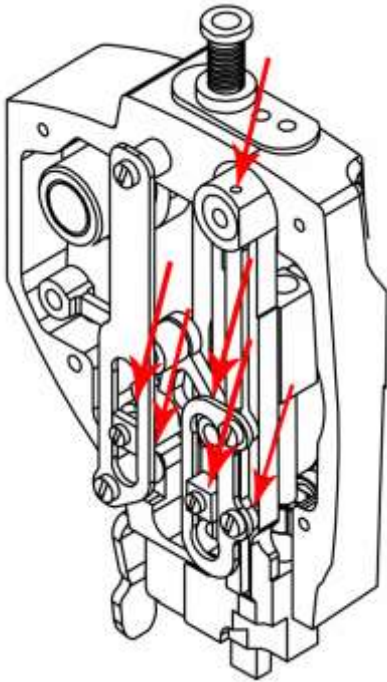

1. Loosen the front cover screws.
2. Remove the front cover.
3. Lubricate each day at the marked points.
4. Replace the cover.
5. Secure with screws.

E1.2. Lubricating the machine head

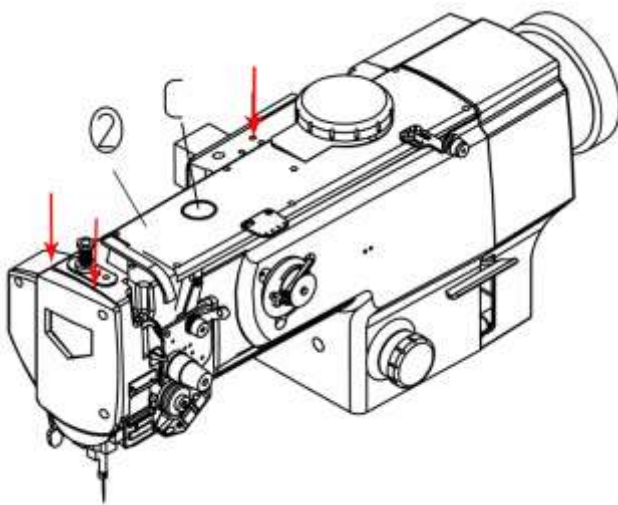

1. The lubrication points (openings) are marked red. Add a few drops of oil to these points every day. If the machine oil could not use all the oil, decrease the frequency of the lubrication.
2. Before first use or after the long-term stop, lubricate the machine at marked points, remove cover ② and apply oil to each felt and hose.
3. "C" is the upper oil tank. Check the operation of the oil pump through the window.

E1.3. Refilling the oil sump

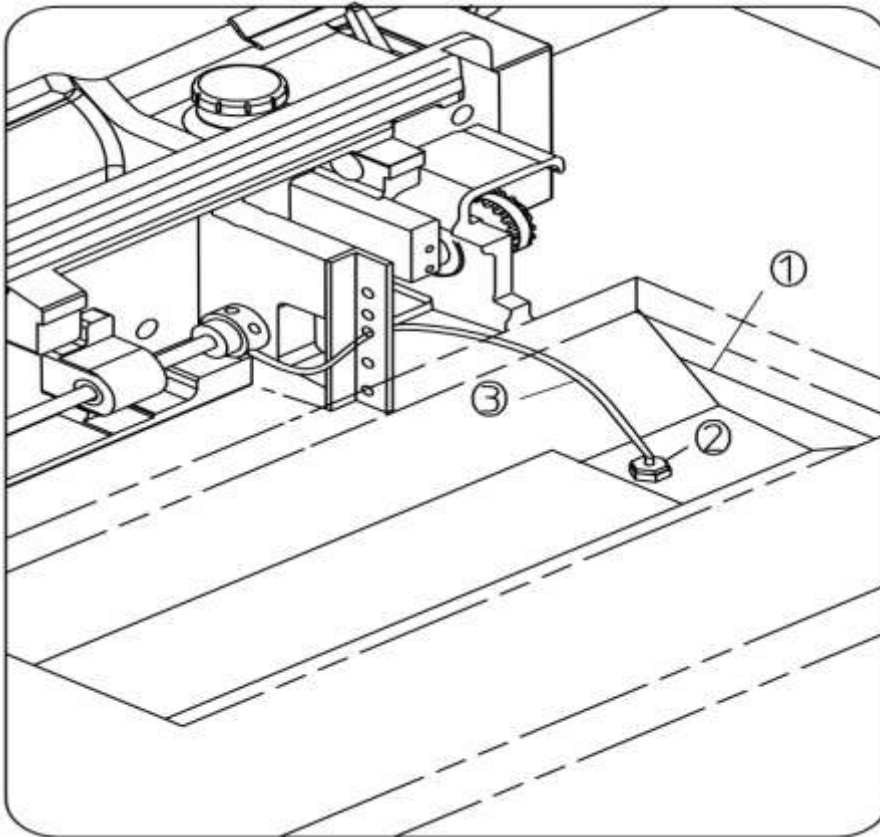

1. Place the oil filter head ② on the hose ③ and put it into the oil sump ① as shown. You can attach it using the magnet.

2 Add the oil until the cap ② is completely submerged.

3. If the oil level falls below 1/3 of the head height ②, add more oil.

E2. ADJUSTING THE LUBRICATION

E2.1. Adjusting the lubrication of the hook

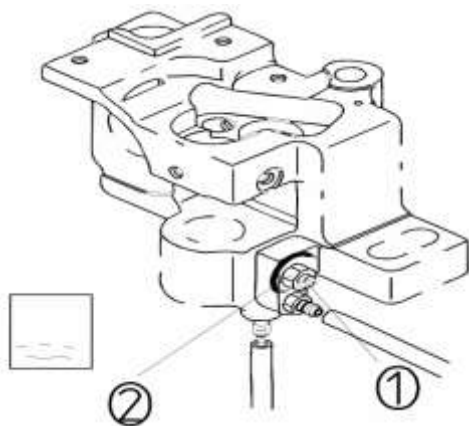

1. Loosen the nut (2) and adjust the amount of lubrication with the screw (1). Turn the screw clockwise to decrease or counterclockwise to increase the amount of oil.

2. Test the proper amount of lubrication with a paper. Place the paper close to the hook and bring the machine to maximum speed for a few seconds. You should see thin lines formed by the oil on the paper.

Too much oil

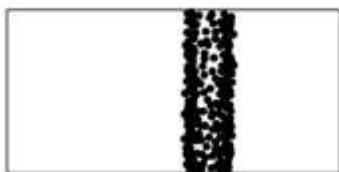

Correct amount of oil

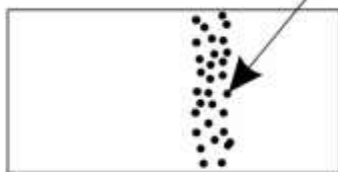

Too little oil



E2.2. Adjusting the lubrication of the upper oil tank

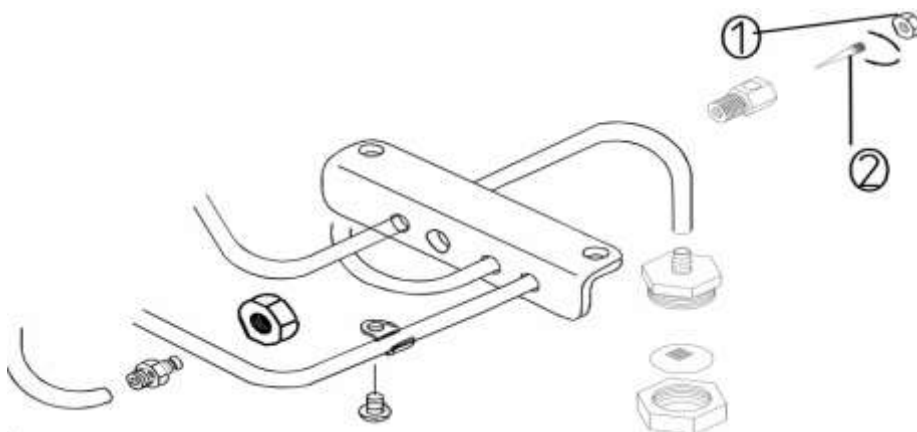

1. If too much oil accumulates in the upper oil tank, tilt the machine head and loosen the nut (1). Turn the screw (2) counterclockwise. If the oil level is too low, turn the screw clockwise.

F TROUBLESHOOTING

Problem	Cause	Solution
1. Broken thread (2 - 3 mm left on the bottom side)	1. Damage into the path of thread, damaged tip of the needle or the hook. 2. Upper thread tension is too high. 3. The needle is touching the tip of the hook. 4. Insufficient oiling of the hook. 5. Upper thread tension is too low. 6. The thread lever spring is too strong, the range of movement is too small. 7. Incorrect timing of the needle and hook.	1. Sand the surface with sandpaper. Sand the hook with a file. 2. Reduce the upper thread tension. 3. Adjust the distance between the needle and the hook (see D8). 4. Adjust the amount of lubrication (see E2). 5. Increase the upper thread tension. 6. Reduce spring force, increase the range of motion. 7. Adjust needle and hook timing (see D8).
2. Skipping stitches	1. Incorrect timing of the needle and hook. 2. Foot pressure too low. 3. Incorrect distance between needle eye and the hook tip. 4. Incorrect needle type.	1. Adjust needle and hook timing (see D8). 2. Increase the foot pressure. 3. Adjust the distance (see D8). 4. Change the needle.
3. Thread too tight	1. Bobbin tension spring too tight. 2. Threads are threaded incorrectly. 3. Bobbin doesn't move. 4. Bottom thread tension is too low. 5. Bottom thread too thick. 6. Damaged tip of the needle.	1. Lower the bottom thread tension. 2. Check the threading of upper and bottom thread. 3. Check the bobbin. 4. Increase the bottom thread tension. 5. Use the thinner thread. 6. Change the needle.

G DRIVE UNIT MANUAL

G1. SAFETY INSTRUCTIONS

- 1) Read the manual carefully before installation and use.
- 2) Installation of the drive unit may only be carried out by a qualified person.
- 3) Follow all instructions indicated by symbols to avoid injury.
- 4) Do not use a multiple socket extension cord.
- 5) Make sure that the power supply and voltage match the requirements on the label of the machine (230V AC in $\pm 10\%$ ranges).
- 6) Do not use in direct sunlight, outdoors. Temperature area is over $5^{\circ}\text{C} \sim 45^{\circ}\text{C}$.
- 7) Do not use close to the heater. Humidity is 80% or less.
- 8) Do not use in dusty, corrosive or explosive environment.
- 9) Do not put heavy objects on the power cord, do not pull it or bend it.
- 10) Proper permanent grounding is necessary.
- 11) Use safety covers for all moving parts.
- 12) Do a test run at the slow speed and check the direction of the rotation.
- 13) Switch off the machine and unplug it in these situations:
 - threading the needle (needles), hooks, etc.
 - changing the needle, presser foot, needle plate, hooks, hook bobbins, feeders, needle guards, finger guards, work guides, etc.
 - the machine is not in use and left unattended
 - opening or removing the protective covers
 - any maintenance, repair, inspection and adjustment of the machine
 - cleaning the machine
- 14) Maintenance, repair, inspection and adjustment of the machine may only be carried out by a qualified person.
- 15) Use only original or approved spare parts from manufacturer.
- 16) All connector shouldn't be plug and unplug when power on.
- 17) When there is water or other liquid, or caustic materials on box or motor, you must stop operation and turn off the power.

G2. DESCRIPTION AND INTENDED USE OF A DRIVE UNIT

The AHC-9090 series are power units that are designated to drive industrial sewing machines and to be built into a sewing machine. They consist of the engine itself, the control box and the control panel (keypad). Other use is not permitted.

G3. DRIVE UNIT TECHNICAL PARAMETERS

Product type	AHC-9090 AC Servo System
Voltage	AC 230 $\pm 10\%$ V
Frequency	50/60 Hz
Max. power	850 W

G4. INSTALLATION AND ADJUSTMENT

G4.1. Dimension of control box and speed controller bracket (direct driven)

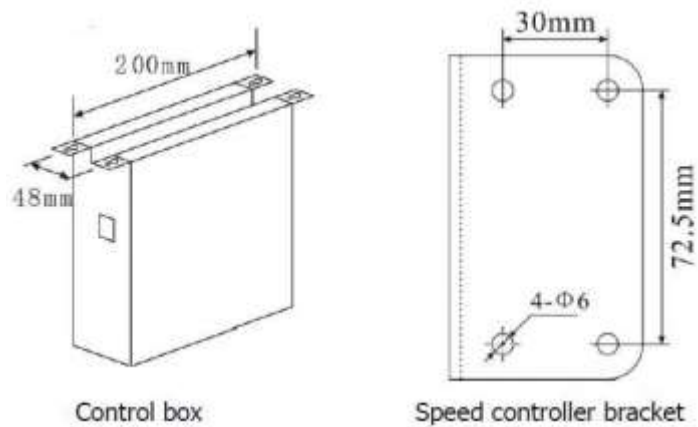

G4.2. Speed controller

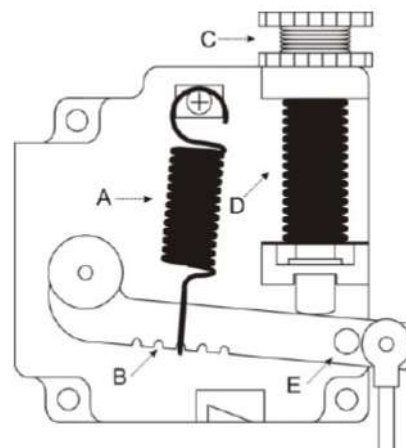
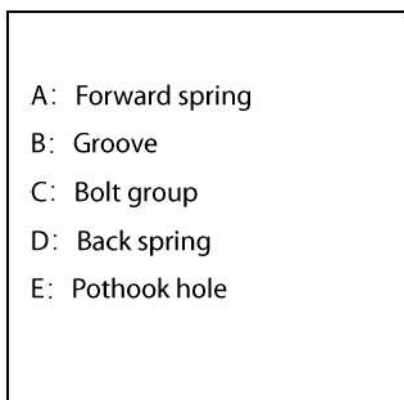

G4.3. Installation diagram of system

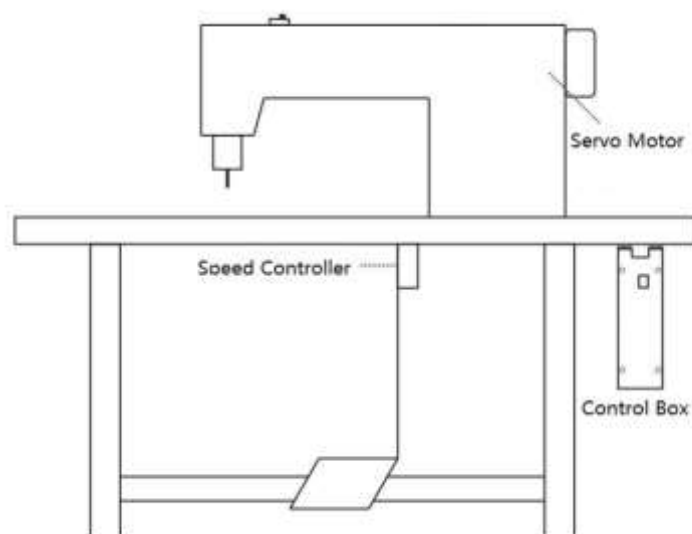

G5. ELECTRICAL CONNECTION

G5.1. Connecting the power supply

Work on the electrical equipment may only be performed by qualified technicians or personal who have undergone the necessary training.

Always pull the power plug before working on the electrical equipment.

Connect the control to a grounded AC voltage, the rated voltage is in the range of 230V+10%

G5.2. Single phase 230V power connection

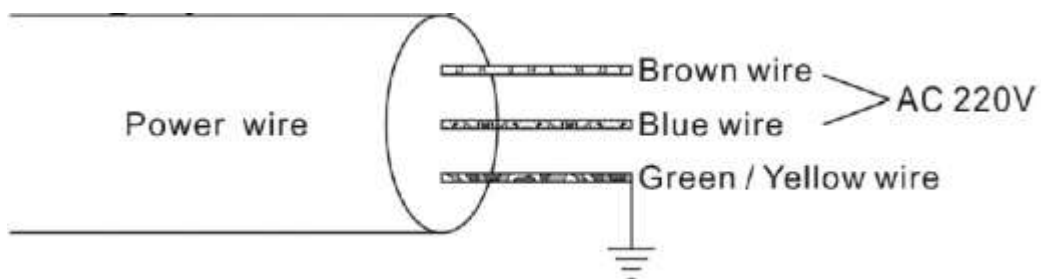



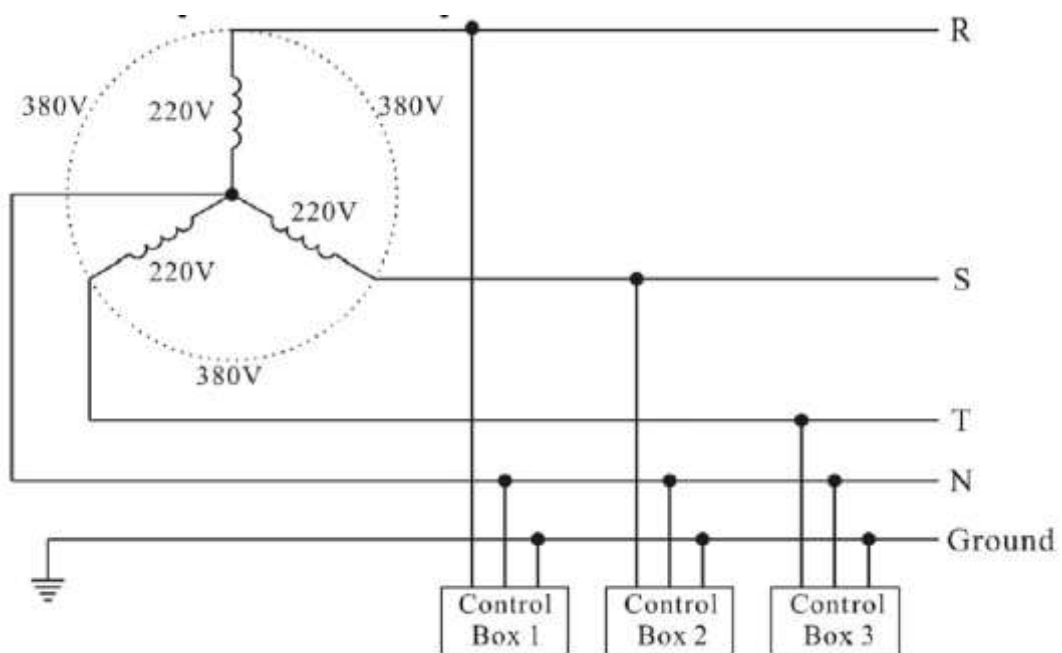



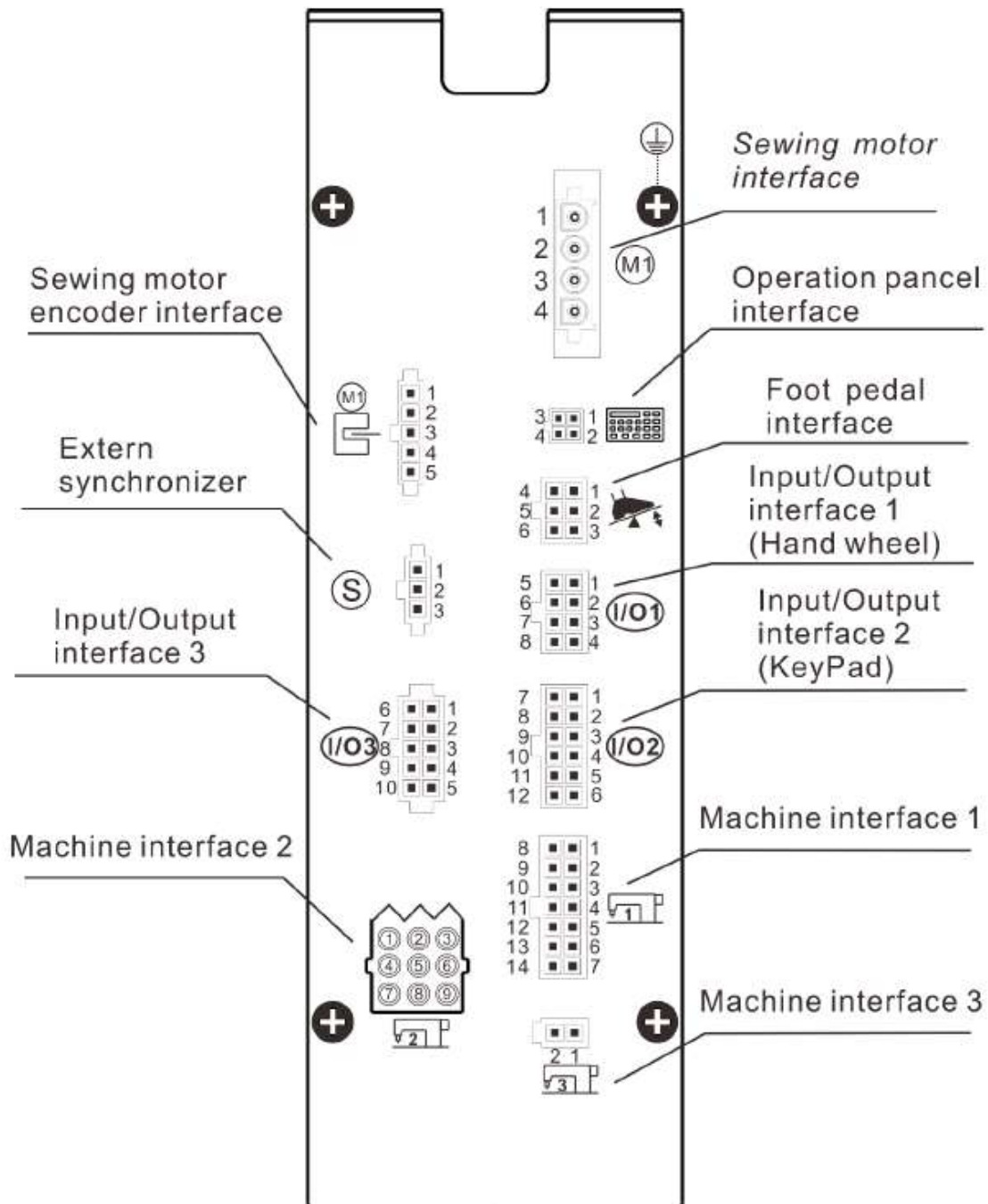

G5.3. Three phase 380V power connection



G6. CONNECTOR DIAGRAM









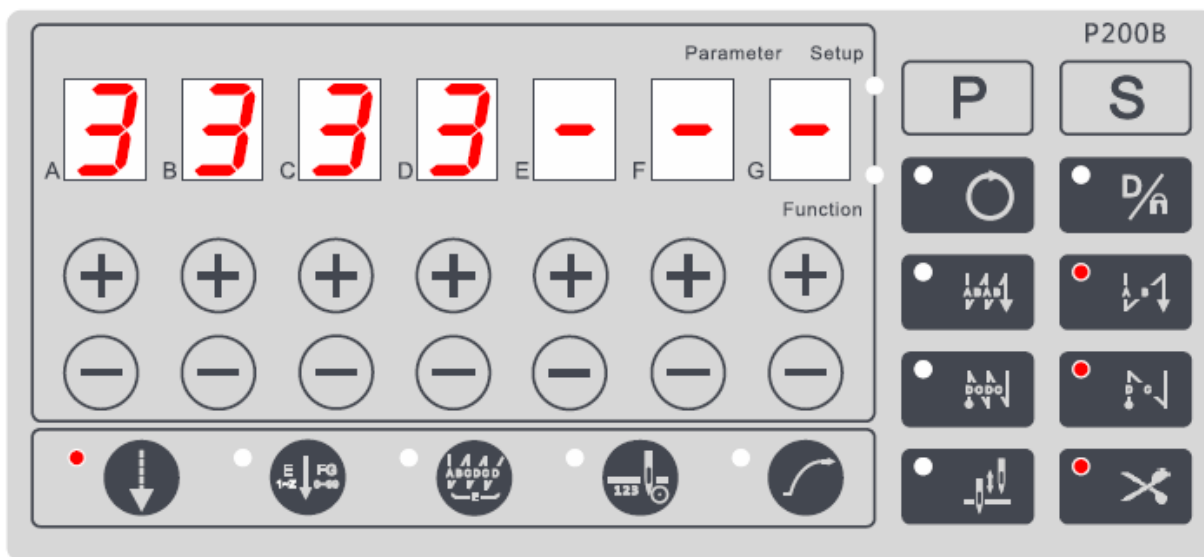









Interface icon	Pin	Definition
	1	EARTH
	2	A phase
	3	B phase
	4	C phase
	1	DC-5V
	2	GNDS
	3	JT-UP
	4	MC-CHA
	5	MC-CHB
	1	VCC
	2	JT-UP-A
	3	GND
	1	VCC
	2	GND
	3	RXD
	4	TXD
	1	Foot
	2	Start
	3	Trim
	4	Pedal
	5	GND
	6	VCC
	1	GND
	2	GND
	3	I013-IN
	4	I07-IN
	5	CHA-IN
	6	CHB-IN
	7	Z-IN
	8	VCC
	1	GND
	2	GND
	3	I012-OUT (Keypad-Clk)
	4	I011-OUT (Keypad-Lock)
	5	I08-IN (Keypad-Key)
	6	VCC
	7	I01-IN (MID SCL)
	8	I05-IN (MID SDA)
	9	I04-IN (Keypad-Reverse SW.)
	10	I09-IN
	11	I010-OUT (Keypad-Shift)
	1	VCC
	2	VCC
	3	AN3-IN
	4	AN1-IN
	5	AN4-IN
	6	VCC
	7	GND
	8	AN2-IN
	9	GND
	10	GND
	1	DC31V
	2	DC31V
	3	DC31V
	4	EARTH
	5	GND
	6	DV31V
	7	GND
	8	Sol Out 1
	9	Sol Out 3

	10	Sol Out 5
	11	Safe SW.
	12	Rev SW.
	13	Sol Out 2
	14	VCC
	1	Sol Out 7
	2	DC31V
	3	DC31V
	4	Sol Out 6
	5	DC31V
	6	Sol Out 8
	7	DC31V
	8	Sol Out 9
	9	
	1	DC31V
	2	Sol Out 4

G7. OPERATING FIELD P200B





Start backtack		Single start tacking, A is the stitches of forth sewing; B is the stitches of back sewing. They are both in range 1~15
		Double start tacking, A is the stitches of forth sewing; B is the stitches of back sewing. They are both in range 1~15.
End backtack		Single end tacking, C is the stitches of back sewing; D is the stitches of forth sewing. They are both in range 1~15
		Double end tacking, C is the stitches of back sewing; D is the stitches of forth sewing. They are both in range 1~15
Free Sewing		<p>▲ As the pedal is stepped forward, the starttacking(if selected) will be done automatically, then machine will start normal sewing. Once the pedal returned to balance, machine will stop immediately.</p> <p>▲ As the pedal stepped backward, the end tacking, trimming and wiping(if selected) will be done automatically</p>
Constant-Stitch Sewing		<p>▲ Once the pedal is stepped forward, F, G stitches will be completed with E times.</p> <p>▲ Constant-Stitch Sewing will perform the number of segments and times as setting, when the stitches are zero, machine will stop immediately.</p>
Bar-Tacking Sewing		<p>▲ Once the pedal is stepped forward, all the seams of bar tacking, A, B, C, D sections will be completed with E times, and the trimming will be done automatically.</p> <p>▲ The pedal must be returned to balance for next sewing.</p>
Lower thread Counter		Enter lower thread counter interface
Soft start		Enable or disable the soft start
Needle Up / Needle Down		Select the stop position of needle bar
Trimming Enable		Enable or disable the trimming
Interface Selection		Switch current interface to another
One-Key Default /Lock keys		<p>▲ Sewing interface: lock the keypad</p> <p>▲ Parameter interface: restore a parameter to default</p>
Parameter Function		Enter or exit parameter function interface
Save		Confirm and save current value of parameter
Add		Value increase
Sub		Value decrease



G8. GET STARTED WITH YOUR MACHINE

Before operating the controller, the following items must be inspected and set up to ensure safe and reliable operation.

G8.1. Machine ID

Press and hold button  under position A and turn on the power to access to adjust the machine ID, seven segment displays F, G will display the ID, change it and press  to save.

G8.2. Adjust the ZERO of the machine

Press  and switch on the power, the panel displays “ZERO”, turn hand wheel slowly, the panel displays the current degree. When the needle bar is at the highest position, press  to confirm and save. Restart the control box.

G9. OPERATING ELEMENTS

G9.1. Single start back-tacking setting

A Stitches = 0. Seven-segment display A [-]. *Sewing process:* B stitches back – normal sewing.
A Stitches ≠ 0. *Sewing process:* A stitches forth - B stitches back – normal sewing.

G9.2. Double start back-tacking setting

A Stitches = 0. *Sewing process:* B stitches back – B stitches forth - B stitches back - normal sewing.
A Stitches ≠ 0. *Sewing process:* A stitches forth - B stitches back – A stitches forth - B stitches back - normal sewing.

G9.3. Single end back-tacking setting

D Stitches = 0. Seven-segment display D [-]. *Sewing process:* C stitches back – end.
D Stitches ≠ 0. *Sewing process:* C stitches forth - D stitches back – end.

G9.4. Double end back-tacking setting

D stitches = 0. *Sewing process:* C stitches back – C stitches forth - C stitches back - end.
D Stitches ≠ 0. *Sewing process:* C stitches back - D stitches forth - C stitches back – D stitches forth - end.

G9.5. Lower thread counter

Set A11(Refer to Parameter list) to “1” to active the counter.

Enter interface: Press  or Special function interface SN F6, refer to G.10.

Initialize the counter: Press , the initial value of the lower thread counter which was set previously will be shown. Adjust it to a suitable value.

How the counter works:

- Display initial value
- The counter reduces by 1 for every 10 stitches sewn.
- If the counter less than 1, the display area twinkled and buzzer sounds for 3 times.



The machine will not start up again. Press  the warning will disappear and sewing will be possible, the counter reduces continue.

- Press  again, the display will return to the initial value.

G9.6. Product quantity counter

Set A11 (Refer to Parameter list) to “1” to activate the counter.

Enter interface: Special function interface SN F2, refer to G.10.

Data acquisition: In SN F2 interface, press  will into collect process interface, seven-segment display D [L], seven-segment display E, F, G will display the number of stitches for this process. It records the number of stitches and the number of trimming. Press  to save the data and return SN F2 interface.

How the counter works: If the sewn the number stitches more than the number of stitches collected 90%, and the number of trimming times more than collected, the counter add 1.

Clear counter: Press .

G9.7. Adjust the backtack

Before adjustment, make sure that forward stitch length is the same with backward figure.

The time it takes for reverse actuator actions, adjust parameter T01 as the guide of following figure

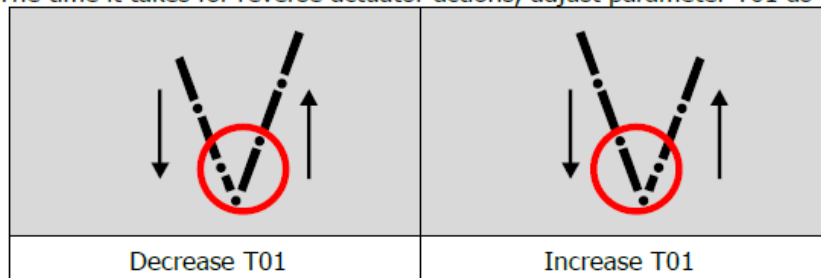

The time it takes for reverse actuator releases, adjust parameter T02 as the guide of following figure.

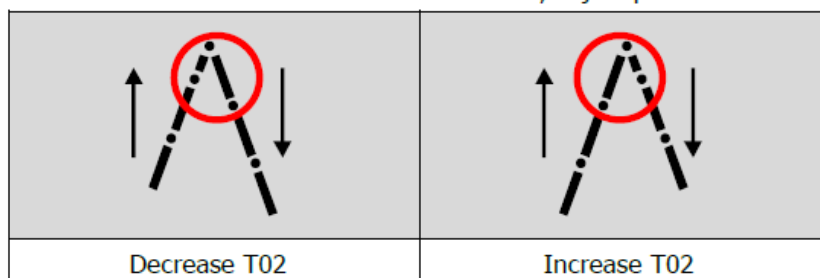

G9.8. Other adjustment

Lock the hot keys and keypad: If  key is triggered, all function on the keypad and hot keys are invalid.

Electronic hand wheel: Turning the hand wheel: The value of “A23” is 1, electronic hand wheel is activated. By turning the hand wheel, you can move the needle bar forwards or backwards.

Hot keys: Pressing the Reverse switch: Default: Reverse. Refer to Parameter list, A04.

Pressing the hand wheel: Default: None. Refer to Parameter list, A05.

Quick stroke adjustment via knee switch: On machines with quick stroke adjustment activated via a knee switch, the elevated sewing foot stroke is switched via the knee switch.

G10. OPERATING OF THE SPECIAL FUNCTION INTERFACE

Press  could be access special function interface, showed as below:

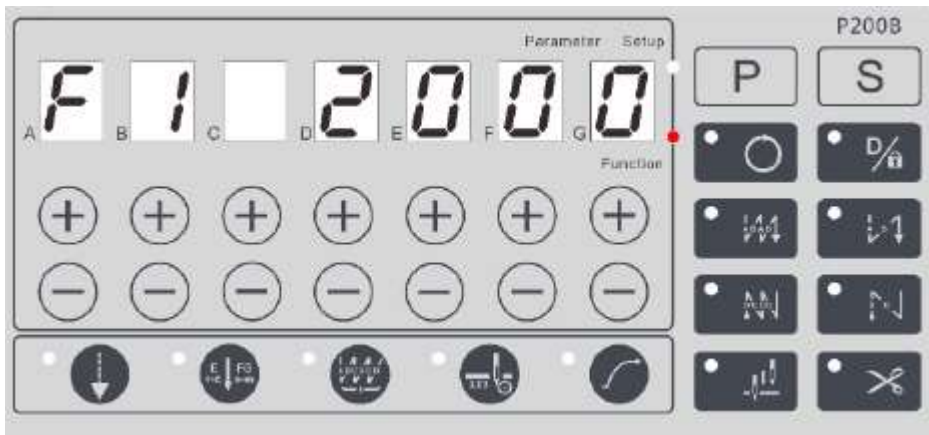

2: Function Interface

Bar A and B according to SN of function, bar D~G display contents, press **B+** and **B-** to select function:

- *Dynamics speed limitation:*

SN F1: display current speed up limitation, could be change during running.

- *Product quantity counter:*

SN F2: Display the product quantity

- *Machine degree:*

SN F3: Display the machine degree

- *Torque enhancement function at low speed:*

SN F4: display D: press **D+** and **D-** to open/close the function.

- *Actual speed display:*

SN F5: display the actual speed

- *Lower thread counter:*

SN F6: display how much the lower thread is remaining

G11. PARAMETER INSTRUCTION



G11.1. Setting parameter

Press  to enter Parameter Interface.

Seven-Segment display E, display the parameter type, press **E+** and **E-** key to change it.

Seven-Segment display F, G display the parameter index, press **F+**, **F-**, **G+**, **G-** key to change it.

Seven-Segment display A, B, C, D display the parameter value, press the keys under them to change it.

For example: parameter index is 1, type is P, value of "S01" is 2000, the tube light blink when change the value. Press  to confirm, press  to cancel and return to sewing interface.

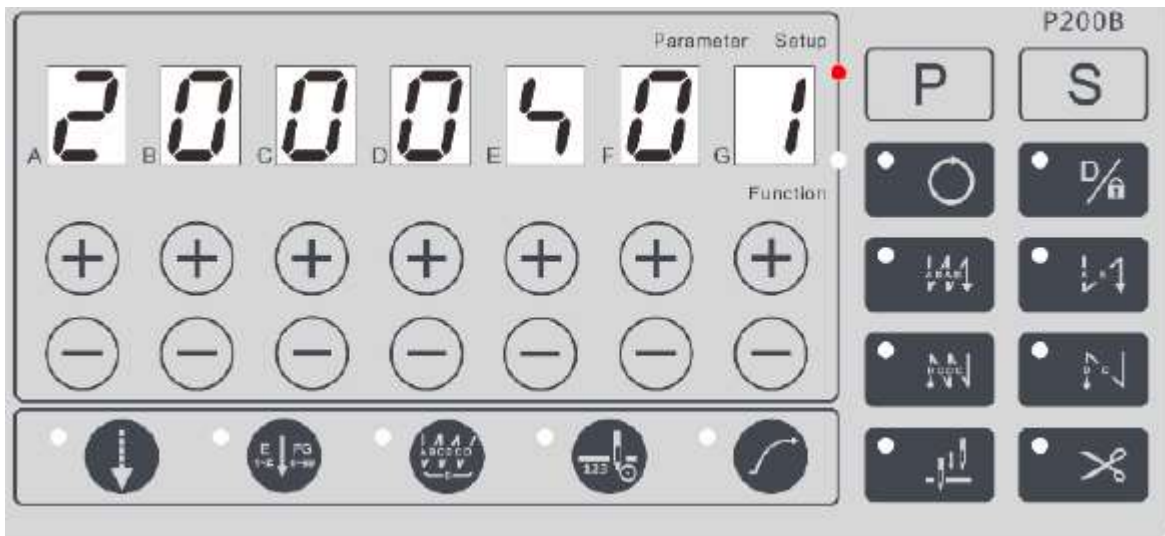

3: Parameter Interface

G11.2. Get the permission of setting 0 type parameter

Only S, T and A type parameter can be select normally. If you want to change the 0 type parameter, you must power on while press **P** key, when you see [DO EN], you get the permission successfully.

G11.3. Parameter solidifying

If users want to change some parameter's default value, then select the parameter, press **○** maintain a moment, after [SD OK] displaying, the default value has been changed.

G11.4. Other Parameter adjustment

- Restore parameter through one-key default

Select any parameter in parameter interface, **D/h** can be used to recall the default value. The bar will be twinkling if modified, use **S** to confirm or **P** to repeal change.

- Controller recovery

Resume the default value parameter of all parameters: Set parameter **017** to "ON", turn on the power again, after twinkling of "INIT" finished, all parameters have been default value themselves.

Restore Factory Defaults: Set parameter **051** to "ON", turn on the power again.

- Abate safety switch

If you want to abate the function of Safe SW, you can change the value of **031** from "1" to "0" normally, in a particular case, for example, the Safe SW broke down, you can power on while press **C+** key to abate the function of Safe SW.

Warning: it means potential security problems for you if you abate the function of Safe SW, so attention please.

G11.5. General parameter table

SN	RANGE	DESCRIPTION
S type Parameter		
S01	500~3500spm	Maximum sewing speed
S02	150~500spm	Minimum sewing speed
S03	500~2000spm	Speed adjustment for start back-tacking
S04	500~2000spm	Speed adjustment for end back-tacking
S05	500~2000spm	Speed adjustment for bar-Tacking
S06	500~2000spm	Speed adjustment for constant-stitch sewing
S07	150~300spm	Speed adjustment for trimmer
S08	200~500spm	Soft start speed
S09	500~3500spm	Speed adjustment for foot stroke gear 1
S10	500~3500spm	Speed adjustment for foot stroke gear 2
S11	500~3500spm	Speed adjustment for foot stroke gear 3
S12	500~3500spm	Speed adjustment for foot stroke gear 4
S13	500~3500spm	Speed adjustment for foot stroke gear 5
S14	500~3500spm	Speed adjustment for foot stroke gear 6
S15	500~3500spm	Speed adjustment for min-foot stroke
S16	50~500spm	Speed adjustment for pull back after trim
T type Parameter		
T01	1~200(millisecond)	Action time of the REV SOL.
T02	1~200(millisecond)	Release time of the REV SOL.
T05	1~500(millisecond)	Foot lifer-Delay time adjustment for pedal's feet lift position
T06	1~500(millisecond)	Running delay time adjustment for Automatic Foot Lifer
T09	1~1000(millisecond)	Safety switch-Delay time adjustment for machine vibration
T10	1~200(millisecond)	Pedal-Delay time adjustment for pedal vibration
T11	1~1000(millisecond)	Delay time adjustment when A20/A22 set as 1
A type Parameter		
A01	0~1	Needle positions 1 = Up Position 0 = Down Position
A02	0~1	Automatic Constant-Stitch sewing 1 = On 0 = Off
A03	0~1	Correction stop mode 1 = stop position accord to D15, D16
A04	0~13	0 = random Function selection of reverse switch 0 = none 1 = reverse 2 = forward correction 3 = backward correction 4 = forward correction at machine stop, reverse at machine run 5 = backward correction at machine stop, reverse at machine run 6 = none 7 = none 8 = trim at normal sewing, foot lifer after trimming 9 = foot stroke 10 = single backtack supression 11 = 2 nd STITCH LENGTH 12 = additional thread tension 13 = thread mode
A05	0~13	Function selection of hand wheel switch, refer to A04
A06	0~1	Trim selection 1 = trimmer valid 0 = trimmer invalid

A07	0~1	Lock machine buttons selection (machine buttons includes Hot Keys, Hand Wheel Switch, Reverse Switch) 0: machine buttons work 1: machine buttons not work
A09	0~1	Foot lifer selection 1: Foot lifer function valid 0: Foot lifer function invalid
A10	0~1	Clamp selection 1: Clamp valid 0: Clamp invalid
A11	0~1	Product Quantity Counter 1 = On 0 = Off
A12	0~1	Bobbin thread Counter 1 = On 0 = Off
A13	0~1	Pull Back after Trim (angle refer to O35) 1 = On 0 = Off
A14	0~1	Automatic Foot Lifer when stopped 1 = ON 0 = Off
A15	0~1	Automatic Foot Lifer after trimming 1 = On 0 = Off
A16	0~1	Automatic constant-stitch sewing after start backtacking (only when A02=0) 1 = On 0 = Off
A17	0~1	Automatic end backtacking for constant-stitch sewing (only when A02=0) 1 = On 0 = Off
A18	0~1	Upper position when switch on the control 1 = On 0 = Off
A19	0~2	Function when Half-Heeling the pedal 2: thread cutting 1: foot lift 0: Balance
A20	0~1	Mode of start back-tacking (only for free sewing) 1: stitch for stitch 0: normal
A21	0~1	Soft start
A22	0~1	Mode of end back-tacking (only for free sewing) 1: stitch for stitch 0: normal
A23	0~1	Electronic handwheel 1 = On 0 = Off
A27	0~3	Mode of thread tension and thread tension reduction when sewing foot lift is active 0 = no thread tension lift 1 = thread tension lift in the seam 2 = thread tension lift after trimming 3 = thread tension lift in the seam and after trimming
A28	0~1	Automatic open additional thread tension when foot stroke adjust 0 = not related to Knee SW. ; not related to Keypad ; 1 = related to Knee SW. ; not related to Keypad ; 2 = not related to Knee SW. ; related to Keypad ; 3 = related to Knee SW. ; related to Keypad ;

A30	0~1	Correction mode 0: single correction 1: continuously correction
A36	0~11	Quick function on the keyboard key1 0: none 1: foot stroke 2: start and end strips 3: forward correction 4: stitch length 5: additional thread tension 6: pause 7: add power when low speed 8: reverse 9: parting foot 10: threading mode 11: backward correction
A37	0~11	Quick function on the keyboard key2 Refer to A36
A38	0~11	Quick function on the keyboard key3 Refer to A36
A39	0~11	Quick function on the keyboard key4 Refer to A36
A40	0~11	Quick function on the keyboard key5 Refer to A36
A41	0~11	Quick function on the keyboard key6 Refer to A36
A43	0~1	Electronic handwheel rotation and motor steering correspondence 0: same 1: opposite
A50	0~1	Start with 2 nd stitch length
A51	0~3	Mode for automatic raising of the seam middle guide 0: Do not raise 1: With sewing foot lift 2: During bark-tacking and reverse 3: During back-tacking and reverse and sewing foot lift
D type Parameter		
D01	0~359(°)	Angle of needle bar up lever
D02	0~359(°)	Angle of needle bar down lever
D03	0~359(°)	Switch-on angle of Trimmer
D04	0~359(°)	Switch-off angle of Trimmer
D05	0~359(°)	Switch-on angle of Reverse SOL.
D06	0~359(°)	Switch-off angle of Reverse SOL.
D07	0~359(°)	Switch-on angle of thread clamp
D08	0~359(°)	Switch-off angle of thread clamp
D13	0~359(°)	Switch-on angle of thread tension
D14	0~359(°)	Switch-off angle of thread tension
D15	0~359(°)	Correction angle 1
D16	0~359(°)	Correction angle 2
D17	0~359(°)	Switch-on angle of short thread trimmer (only for TW1-999L14D3T5-001)
D18	0~359(°)	Switch-off angle of short thread trimmer (only for TW1-999L14D3T5-001)

O type Parameter		
O01	1~10(stitch)	Number of soft start stitches
O04	1~1000(millisecond)	Delay time for stitch for stitch backtrack. Refer to A20
O06	0~1	Automatic foot lifter release 1 = Automatic foot lifter release after the time of O07 0 = always hold
O07	5~30(second)	Refer to O06
O17	0~1	Refer to 5.5
O23	1~60(second)	The running time of aging test
O24	1~60(second)	The idle time of aging test
O25	1~720(hour)	The total time of aging test
O26	0~2	Set to "1/2" active the aging test
O31	0~1	Safety switch function 1 = open 0 = close
O32	0~1	Polarity of safety switch 0 = Normal closed 1 = Normal opened
O35	0~359	Angle of pull back after trimming
O48	0~100	The duty of clamp SOL
O51	0~1	Refer to 5.5
O56	0~4095	Pedal input MAX value: value \geq O57
O57	0~4095	Pedal input dividing value of high speed and low speed: O56 \geq value \geq O58
O58	0~4095	Pedal input dividing value of low speed and Balance: O57 \geq value \geq O59
O59	0~4095	Pedal input dividing value of Balance and Foot lifter: O58 \geq value \geq O60
O60	0~4095	Pedal input dividing value of Foot lifter and Trimming: O59 \geq value \geq O61
O61	0~4095	Pedal input MIN value: value \leq O60
O63	0~5	Pedal mode 0 = linear 1 = polyline 2 = curve(slow \rightarrow quick) 3 = curve(quick \rightarrow slow); 4 = S curve(slow \rightarrow quick \rightarrow slow) 5 = S curve(quick \rightarrow slow \rightarrow quick)
O64	500~5000	The speed of turning point when O63 set as 1
O65	0~4095	The value of turning point: O56 \geq value \geq O57
O69	0~1	Correction mode 0 = only the machine stopped 1 = before trimming
O83	0~720	Step width for electronic hand wheel
O84	0~200	Speed for electronic hand wheel
O91	1~10	Stitches of start with 2 nd stitch length

G12. ERROR MESSAGE, POSSIBLE TROUBLESHOOTING

ERROE CODE	DESCRIPTION	SOLUTION
PEDAL	Pedal warning	<ul style="list-style-type: none"> - Check or replace the pedal - Pedal not connected - Do not pedal yet
CARE	Safe Switch problem	<ul style="list-style-type: none"> - Check the Safe Switch - Replace the safe switch
KEY1	Machine button warning	<ul style="list-style-type: none"> - Do not press machine button - Replace the buttons
E101	High AC voltage fault	<ul style="list-style-type: none"> - Check power supply - Stabilize ac voltage - Use generator
E103	High Bus voltage fault	<ul style="list-style-type: none"> - Check power supply - Stabilize ac voltage - Use generator
E106	Bus current overload	<ul style="list-style-type: none"> - Check the encoder and motor - Replace the encoder - Replace the motor
E107	Motor blocked	<ul style="list-style-type: none"> - Eliminate stiff movement in the machine - Replace the encoder - Replace the motor
E110	Encoder/Synchronizer fault	<ul style="list-style-type: none"> - check or replace the synchronizer for a belt-drive machine - check or replace the encoder for a direct-drive machine
E190, E290	Software Update Error	<ul style="list-style-type: none"> - Software update - Replace the control
E191, E291	Software Update Error	<ul style="list-style-type: none"> - Software update - Replace the control
E193, E293	Software Update Error	<ul style="list-style-type: none"> - Software update - Replace the control
E294	Software Update Communication Error	<ul style="list-style-type: none"> - Software update - Replace the control
E199	Software Update Error	<ul style="list-style-type: none"> - Software update - Replace the control
E900	Communication problem	<ul style="list-style-type: none"> - Restart the control - Replace the control

G13. CONTROLLER CHECK

Press hold  during power on, it will display "TEST" and then enter the Check interface. Seven-Segment display A display check index, the else display contents.

Pedal

Display B,C shows the pedal position status, display D,E,F,G display sample value.

bL	Balance position
L4	Low-speed position, is stepping on the first paragraph
H4	High-speed position, is stepping on the second paragraph
FP	Foot position, anti-step on the first paragraph
FN	Trim position, anti-step on the second paragraph
Er	Not connected or the pedal is faulty

Synchronizer



Turning the motor, display C value changes from 0 to 1.

Position encoder: turning the motor, display D,E,F,G value changes between 0 to 720.

Keypad Test

Display B, C, D, E, F, G correspond to the six keys on keypad, when press the key, the

corresponding display will change from 0 to 1, press  to light on the corresponding LED,

press  to light off,  to light on all and  to light off all, the correspondence between the digital tube and the function key is as follows:

Display B: foot stroke

Display C: start and end trips

Display D: position of the needle

Display E: stitch length

Display F: additional thread tension

Display G: pause

Motor EncoderOutput Device

Click **G+**, **G-** to change output index, press  to test.

Input Switches

Display C: status of Reverse switch

Display E: status of Safety Switch

Display G: Encoder

Electronic Handwheel

Display B: Rotation

Display C: Press Switch

Display DEFG: Encoder



Speed Limit Device to stroke

Digital Type: four gears

- Display C shows gear, display E, G display the status of the two switches inside.

Analog Type: Stepless speed change

- Display D, E, F, G shows the sample value of the potentiometer.

- Adjustment: press  to save two gear position, and press  to save six gear position.

AC Voltage

Display the current AC input voltage

e.g.: , AC voltage 220V.

Bus Voltage

Display the current bus input voltage

e.g.: , bus voltage 310V.

A phase current sampling reference

B phase current sampling reference

AD1 sample value

AD2 sample value

AD3 sample value

AD4 sample value

Main MCU Software version

e.g.: , version 1.00

Software Release Date

e.g.: , released on October 1, 2016

Slave MCU Software Version

e.g.: , version 1.00

G14. APPENDIX

Seven-Segment Display Characters Compare Table

0	1	2	3	4	5	6	7	8	9
A	B	C	D	E	F	G	H	I	J
K	L	M	N	O	P	Q	R	S	T
U	V	W	X	Y	Z				

How to update the control box with the update module

User can update software of control box by update module if necessary, the operation showed as below:

- Switch off the power, plug the update module into speed controller
- Switch on the power, upgrading starts automatically, it will be accomplished after "ALL OK" displayed. Then switch off and plug the speed controller, all function will be normal after switch on again.

H SPARE PARTS BOOK

H1. FRAME & COVERS

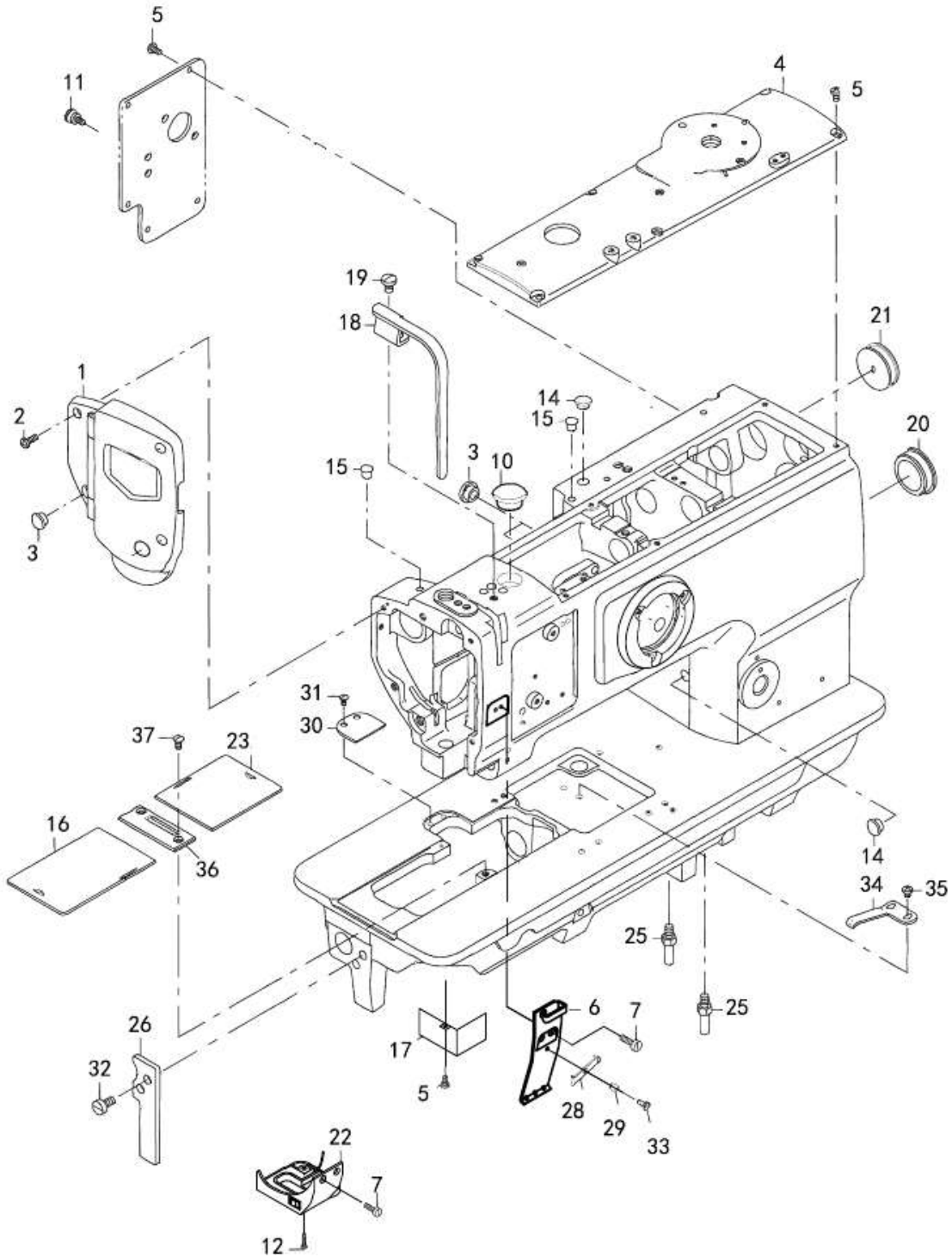

H1. FRAME & COVERS			
Ref. No	Part No.	Part Name	Qty
1	40016798	FACE PLATE ASM.	1
2	SS4111215SP	SCREW 11/64-40 L=12	3
3	TA1250406RO	LUBRICATION SUPPLEMENT	2
4	21331301	TOP COVER B	1
5	SS4110815SP	SCREW 11/64-40 L=8	12
6	020182	THREAD GUIDE PLATE	1
7	SS05090610SP	SCREW 9/64-40 L=9	4
10	020181	RUBBER PLUG	2
11	21331202	SETSCREW	1
12	SS6091022TP	SCREW	2
14	TA1050504RO	RUBBER PLUG	1
15	TA1050504RO	RUBBER PLUG	1
16	21349600	BED SLIDE(LEFT) A	1
17	21332200	OIL BAFFLE PLATE	1
18	21331608	BALANCE COVER	1
19	SS7150910TP	SCREW 15/64-28 L=9	1
20	22619100A	CAP	1
21	10201200A	RUBBER PLUG	1
22	020186	LIGHTING ASM.	1
23	21349808	BED SLIDE(RIGHT) A	1
25	22602601	BED SCREW STUD	2
26	21361407	BED SUPPORT PLATE	1
28	17912106	NEEDLE THREAD PRESSER PLATE	1
29	B1132521000	THREAD PRESSER PLATE SPRING	1
30	22651202	AUXILIARY COVER	1
31	SS2090710TP	SCREW 9/64-40 L=7.2	2
32	SS6151210SP	SCREW 15/64-28 L=12	2
33	SD0380551SL	HINGE SCREW D= 3.80 H= 5.5	1
34	B1111563000	BED SLIDE SPRING	1
35	SS4110515SP	SCREW 11/64-40 L=5	2
36	B1109562D00A	NEEDLE PLATE	1
37	SS2110920TP	SCREW 11/64-40 L=8.5	2

H2. TAKE-UP AND UPPER SHAFT COMPONENTS

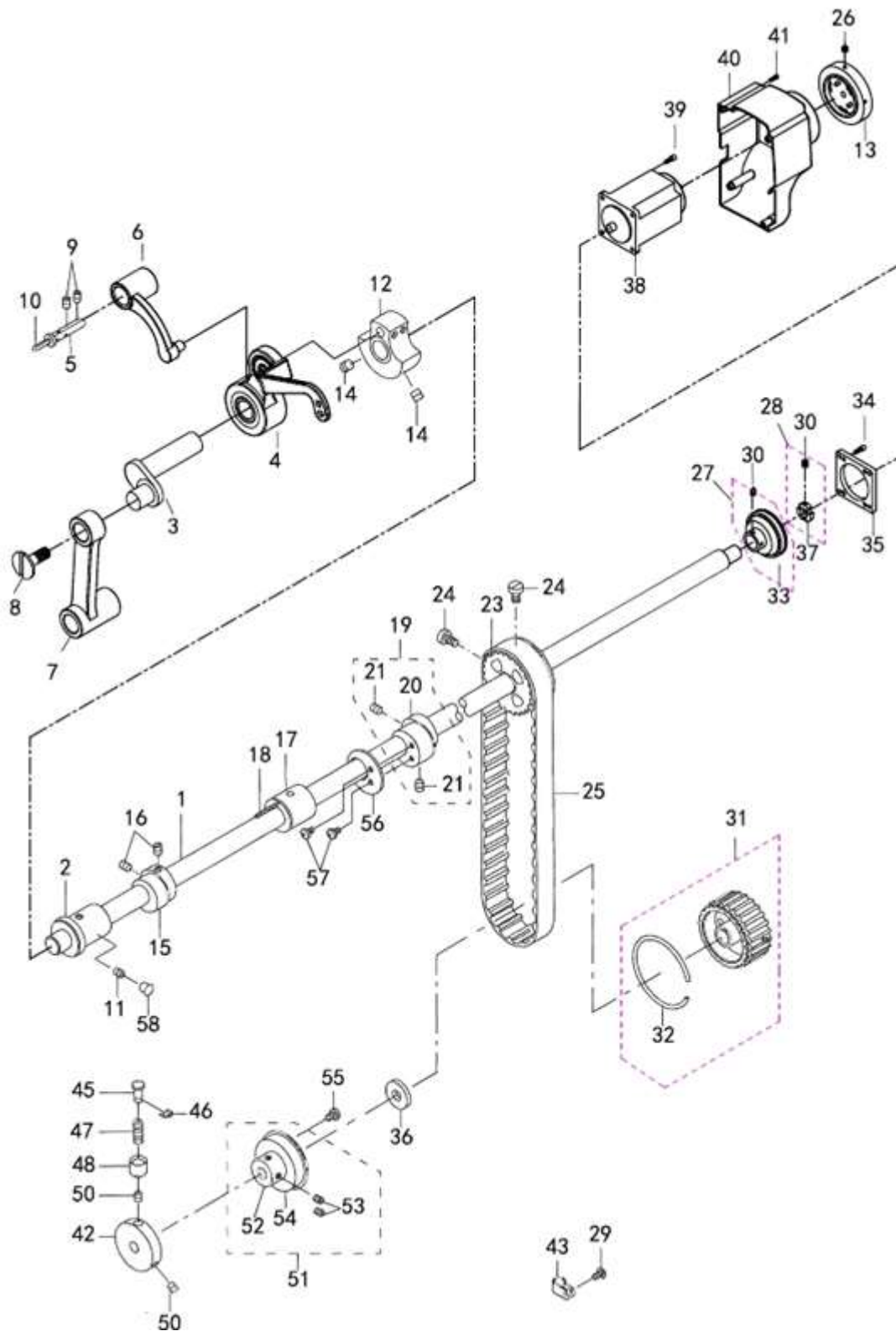

H2. TAKE UP AND UPPER SHAFT COMPONENTS

Ref. No	Part No.	Part Name	Qty
1	010243	UPPER SHAFT	1

2	21333000	UPPER SHAFT FRONT METAL	1
3	010240	CRANK SHAFT	1
4	010235	TAKE-UP LEVER	1
5	B1906051000B	TAKE-UP LEVER PIN	1
6	010241	CURVED CONNETING ROD	1
7	010242	PIN CRANK	1
8	010247	SCREW	1
9	SS8150822TP	SCREW 15/64-28 L=8	1
10	SS8150710TP	SCREW 15/64-28 L=7	3
11	SS8150710TP	SCREW 15/64-28 L=7	1
12	010239	COUNTER WEIGHT (A) (40MM)	1
13	010245	FLYWHEEL	1
14	SM8080812TP	SCREW M8X8	2
15	21339502	UPPER FEED CAM (3.5)	1
16	SS8660810TP	SCREW 1/4-40 L=8	2
17	21333109	UPPER SHAFT INNER METAL	1
18	CQ202000000	OIL WICK	0.15
19	21336557	ECCENTRIC CAM A ASM.	1
20	21336508	ECCENTRIC CAM A	1
21	SS8660810TP	SCREW 1/4-40 L=8	2
23	22604904	UPPER SPROCKET	1
24	SS6661110SP	SCREW 1/4-40 L=11	2
25	22604300	TIMING BELT	1
26	SS8150822TP	SCREW	2
27	010262	BEARING A	1
28	010263	BEARING B	1
29	SS4110815SP	SCREW 11/64-40 L=8	1
30	010258	SCREW	4
31	21387501	LOWER SPROCKET	1
32	B1214019000	SPROCKET RING	1
33	010254	BEARING A	1
34	SS4110815SP	SCREW 11/64-40 L=8	4
35	010256	MOTOR PLATE	1
36	40016148	THRUST COLLAR B WASHER	1
37	010255	BEARING B	1
38	MDBMASD58A850A	MOTOR	1
39	LS5A16	SCREW	4
40	010153	MOTOR COVER	1
41	010426	SCREW	3
42	21333901	SAFETY CLUTCH DISC	1
43	HX00123000A	CABLE CLIP	1
45	21333802	SAFETY CLUTCH PUSH BUTTON	1
46	RE0500000K0	E-RING	1
47	B1639051000	SPRING	1
48	B1313055000	SAFETY CLUTCH KNOB SLEEVE	1
50	SS8660530TP	SCREW 1/4-40 L= 4.5	2
51	40038700	THRUST COLLAR ASM.	1
52	40038702	THRUST COLLAR	(1)
53	SS8661030SP	SCREW 1/4-40 L=10	(2)
54	SB120000200	BEARING 20X42	1
55	SS7120760SP	SCREW 3/16-28 L= 7.0	2
56	21353008	HORIZONTAL FEED CAM COVER	1
57	SS7110710SP	SCREW 11/64-40 L=7	2
58	TA0750704R0	RUBBER PLUG	1

H3. NEEDLE BAR ROCKING

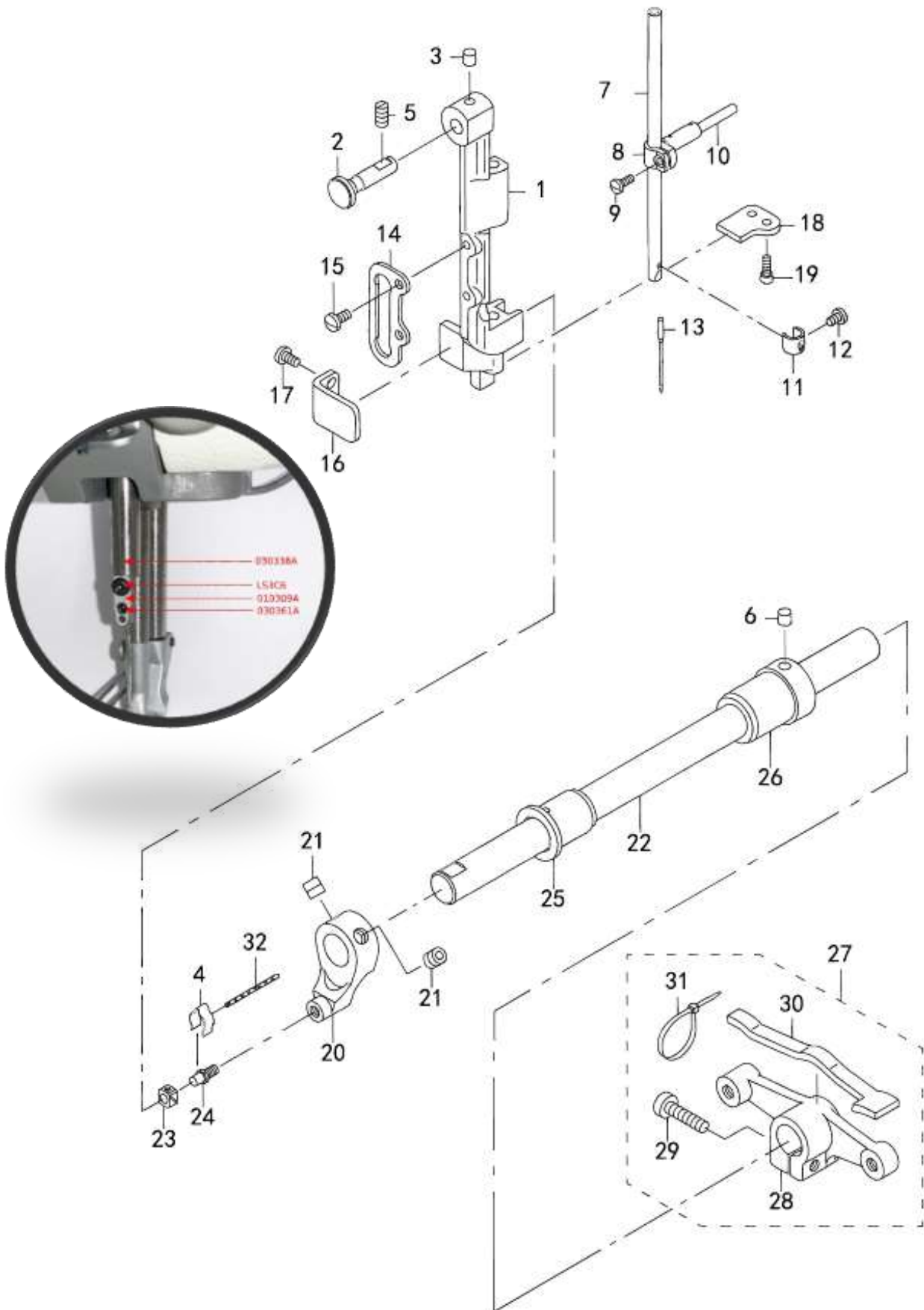

H3. NEEDLE BAR ROCKING			
Ref. No	Part No.	Part Name	Qty
1	23002009	NEEDLE BAR FRAME	1
2	21405204	HINGE STUD	1
3	22814909	FELT	1
4	B1437051000	OIL WICK RETAINER	1
5	SS8151150TP	SCREW 15/64-28 L=10.5	1
6	22814909	FELT	1
7	030338	NEEDLE BAR	1
7	030338A	NEEDLE BAR (NEW TYPE)	1
8	B1411057000	NEEDLE ROD HOLDER	1
9	SS7090910SP	SCREW 9/64-40 L= 8.5	1
10	CQ202000000	OIL WICK	0.04
11	10308609	THREAD GUIDE	1
11	010309A	THREAD GUIDE (NEW TYPE)	1
12	SS7080510TP	SCREW 1/8-44 L=4.5	1
12	030361A	SCREW FOR NEEDLE	1
13	MC372001600	NEEDLE SY3355 160	1
14	41438007	UPPER FEED BAR GUIDE	1
15	SS7110910TP	SCREW 11/64-40 L= 8.5	2
16	21388400	ROCKING BASE GUIDE	1
17	SS7110830SP	SCREW 11/64-40 L= 7.5	2
18	21338603A	ROCKING BASE GUIDE (B)	1
19	SS6091022TP	SCREW	2
20	21338801	ROCKING FRONT ARM	1
21	SM8080812TP	SCREW	2
22	21338900	ROCKING SHAFT	1
23	B1414232000	SQUARE BLOCK	1
24	B1410771000	STUD	1
25	21339304	ROCKING SHAFT FRONT METAL	1
26	40027746	BUSHING REAR	1
27	21339056	ROCKING REAR ARM ASM.	1
28	21339007	ROCKING REAR ARM	1
29	SS6152440SP	SCREW 15/64-28 L=23.5	-1
30	21347406	ROCKING REAR ARM FELT	1
31	EA9500B0000	CABLE BAND	2
32	CQ202000000	OIL WICK	0.05

H4. PRESSURE ADJUSTING & UPPER FEED MECHANISM (1/2)

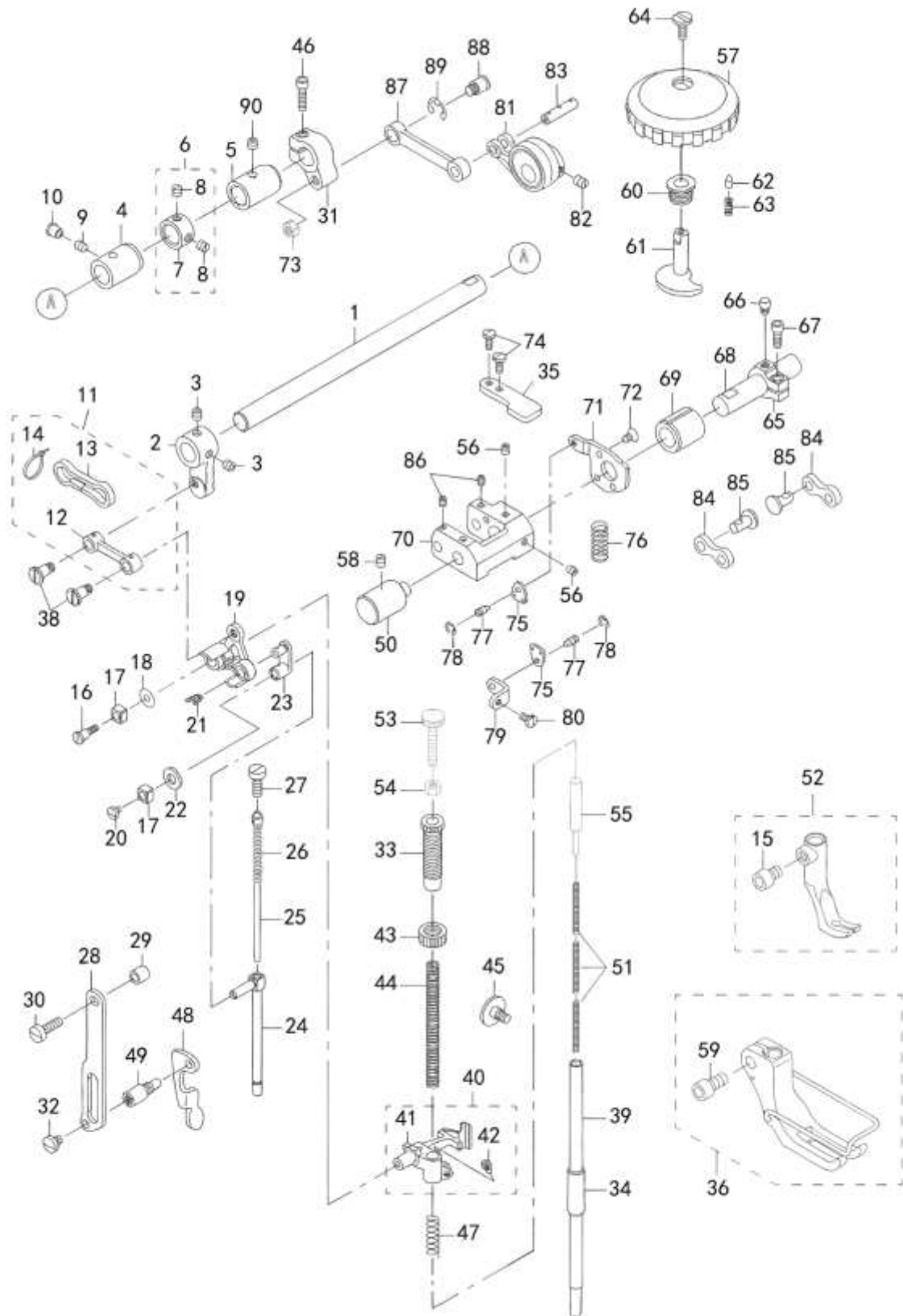

H4. PRESSURE ADJUSTING & UPPER FEED MECHANISM (1/2)			
Ref. No	Part No.	Part Name	Qty
1	21340401	UPPER FEED SHAFT	1
2	21340500	UPPER FEED FRONT ARM	1
3	SS8660612TP	SCREW 1/4-40 L=6	2
4	21341904	FRONT METAL	1
5	21378302	FEED SHAFT METAL	1
6	22904155	MAIN SHAFT THRUST COLLAR ASM.	1
7	22904106	MAIN SHAFT THRUST COLLAR	-1
8	SS8660610TP	SCREW 1/4-40 L=6	2
9	SS8150822TP	SCREW 15/64-28 L=7	1
10	TA0750704RO	RUBBER PLUG	1
11	40033027	UPPER FEED LINK ASM.	1
12	40033026	UPPER FEED LINK	-1
13	21347109	FELT	-1
14	EA9500B0000	CLIP CV-70S	-2
15	SM6040552TP	SCREW M4 L=4.5	-1
16	SD0640701SP	SCREW	1
17	B1414555000	SLIDE BLOCK	2
18	WP0501046SC	WASHER 5 X 13 X 1	1
19	40033029	TRIANGULAR LEVER ASM.	1
20	SS7110510SP	SCREW 11/64-40 L=5	1
21	CQ202000000	OIL WICK	0.02
22	10509701	FELT	1
23	0145653000L	WALKING BAR DRIVING LINK	1
24	40033030	WALKING BAR A	1
25	B14670530A0	WALKING BAR ASM.	1
26	B1468053000	WALKING BAR SPRING	1
27	SS6151780SP	SCREW 15/64-28 L=17.0	1
28	21406509	UPPER FEED GUIDE PLATE	1
29	26225201	ROLLER	
30	SS6151920SP	SCREW 15/64-28 L=19.0	1
31	21340302	UPPER FEED REAR ARM (B)	1
32	SS7150740SP	SCREW 15/64-28 L=7	1
33	21006408	ADJUST SCREW A	1
34	B1510155000	PRESSER BAR LOWER BUSHING	1
35	21339700	UPPER FEED STOPPER PLATE	1
36	40017266	PRESSER FOOT ASM.	1
37	SS4110815SP	SCREW 1/4-40 L=8	2
38	40018340	SCREW	2
39	B1501241H00	PRESSER BAR	1
40	40039265	PRESSER BAR HOLDER A ASM.	1
41	40039266	PRESSER BAR HOLDER A	1
42	SS7110910TP	SCREW 11/64-40 L= 8.5	1
43	22907604	PRESSER SPRING REGULATOR NUT	1
44	B1502246000	PRESSER SPRING	1
45	SD0800481SP	HINGE SCREW D= 8 H= 4.9	1
46	SM6052002TP	SCREW M5 L=20	1
47	B1462053000	THREAD RELEASE SPRING	1
48	21406103	PRESSER LIFTER LEVER	1
49	21406608	GUIDE PLATE SPACER	1
50	21337803	FEED ADJUSTING BASE SUPPORT	1

H5. PRESSURE ADJUSTING & UPPER FEED MECHANISM (2/2)

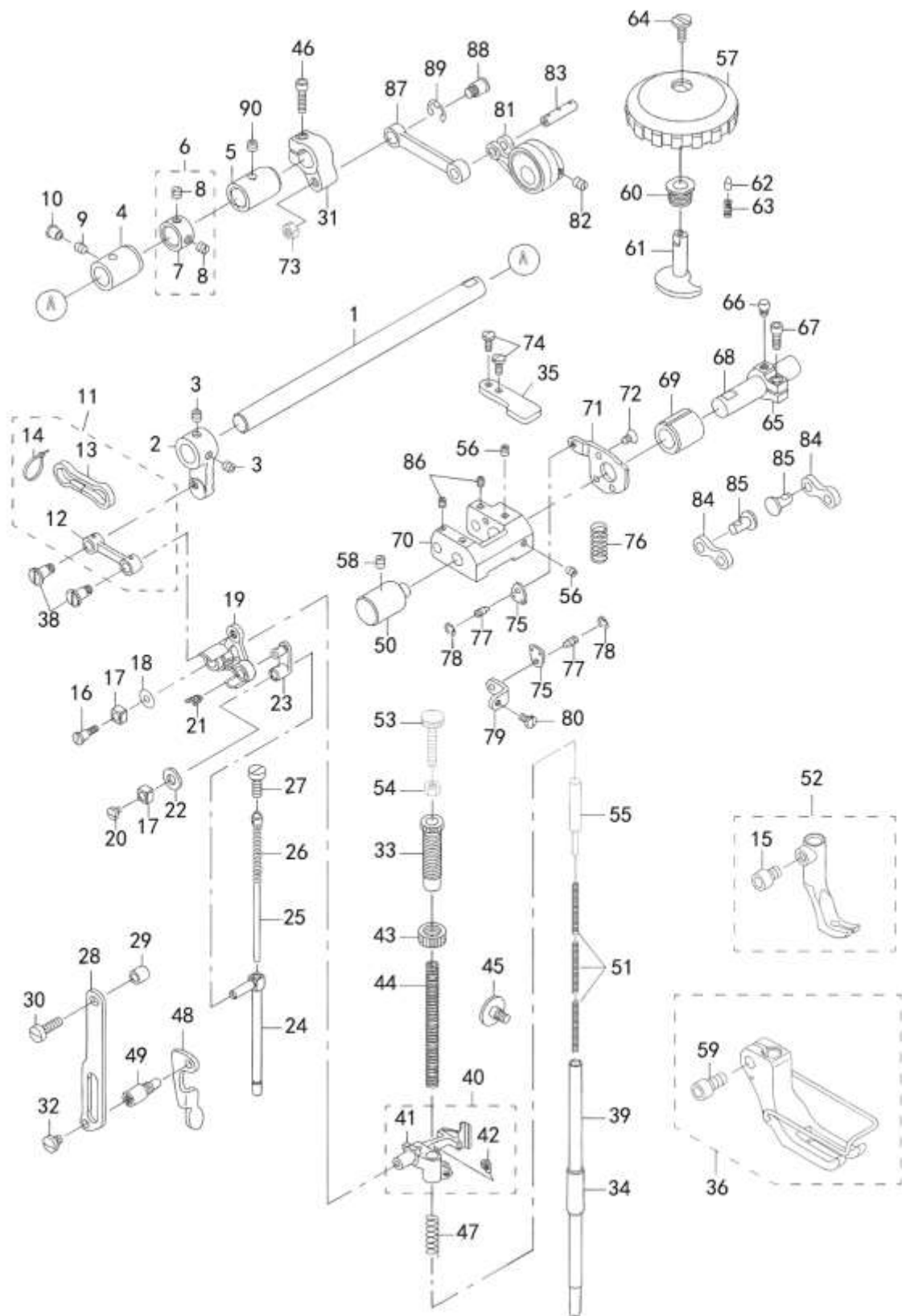

H5. PRESSURE ADJUSTING & UPPER FEED MECHANISM (2/2)			
Ref. No	Part No.	Part Name	Qty
51	21006002	ADJUST SPRING B	3
52	21444559	WALKING FOOT ASM.	1
53	21006507	ADJUST SCREW B	1
54	NS6110530SP	NUT 11/64-40	1
55	40072709	SPRING SUPPORT SHAFT ASM.	1
56	SM8050602TP	SCREW M5 L=6	2
57	10774354	UPPER AND LOWER DIAL ASM.	(1)
58	SS8150710SP	SCREW 15/64-28 L=7	1
59	SM6040802TP	SCREW M4X0.7 L=8	-1
60	10715100	VERTICAL DIAL SHAFT BUSHING	1
61	10715001	VERTICAL ADJUSTING CAM	1
62	10715704	VERTICAL DIAL PIN	1
63	B152652700G	SPRING	1
64	SS6110630TP	SCREW 11/64-40 L=6	1
65	21341607	VERTICAL ADJUSTING ARM	1
66	10715308	PIN	1
67	SM6051402TP	SCREW M5X0.8 L=14	1
68	21341508	VERTICAL CHANGE BASE SHAFT	1
69	10718203A	FEED SHAFT FRONT METAL	1
70	10714202	VERTICAL CHANGE BELT	1
71	21438106	STOPPER PLATE B	1
72	SM1050801SR	SCREW M5 L=8	1
73	NS6680320SP	NUT 9/32-28	1
74	SS4110815SP	SCREW	2
75	10713501	SPRING HOOK	2
76	10716504	VERTICAL SHAFT SPRING	1
77	B3416552000	CONNECTING ROD HINGE SCREW	2
78	RE0500000K0	E-RING	2
79	21339809	UPPER FEED DOG SPRING HOOK	1
80	SS7110830SP	SCREW 11/64-40 L= 7.5	1
81	10713766	ECCENTRIC ROD (SET)	1
82	SS8660810TP	SCREW 1/4-40 L=8	2
83	10713808	CONNECTION LINK PIN B	1
84	10714509	CONNECTION LINK B	2
85	10714608	CONNECTION LINK B SUPPORT PIN	2
86	SM8050602TP	SCREW M5 L=6	2
87	21340005	UPPER FEED LINK (B)	1
88	21048707A	HINGE SCREW	1
89	RE0800000K0	E-SHAPED SNAP RING (8MM)	1
90	SS4110815SP	SCREW 11/64-40 L=8	1

H6. FEED MECHANISM (1/2)

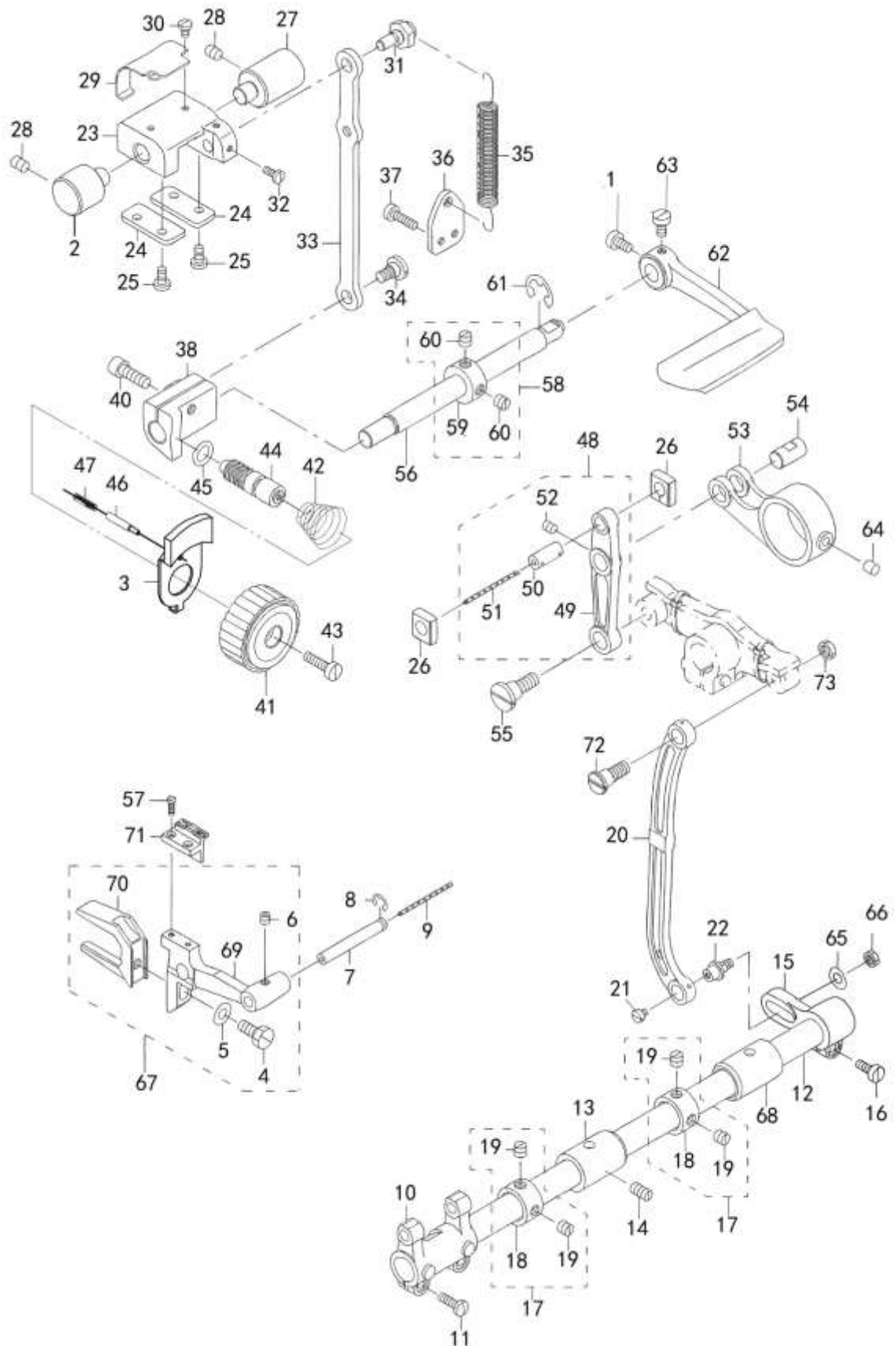

H6. FEED MECHANISM (1/2)			
Ref. No	Part No.	Part Name	Qty
1	SS7150910TP	SCREW 15/64-28 L=9	1
2	21430400	FEED ADJUSTING BASE SUPPORT	1
3	010561	BOTTON	1
4	SS9151440CP	SCREW 15/64-28 L=14	(1)
5	WP0621016SD	WASHER 6.2X13X1	(1)
6	SM8050502TP	SCREW M5 L=5	(1)
7	B1604012000A	FEED BAR SHAFT	1
8	RE0500711KP	SNAP RING 5	1
9	CQ202000000	OIL WICK	0.14
10	21364104	FEED ROCKER	1
11	SS7111410SP	SCREW 11/64-40 L=14	2
12	020573	FEED ROCK SHAFT	1
13	21378302	FEED SHAFT METAL	1
14	020514	SCREW 11/64-40 L=8.5	2
15	22609309L	FEED ROCKER SHAFT CRANK	1
16	SS6121610TP	SCREW 3/16-28 L=15.5	1
17	22904155	MAIN SHAFT THRUST COLLAR ASM.	2
18	22904106	MAIN SHAFT THRUST COLLAR	(1)
19	SS8660610TP	SCREW 1/4-40 L=6	(2)
20	020574	NEEDLE BAR FRAME ROD	1
21	SS6110630TP	SCREW 11/64-40 L=6	1
22	21378203	FEED ROCK SHAFT HINGE SCREW	1
23	21337506	FEED ADJUSTING BASE	1
24	21337704	FEED ADJUSTING BASE COVER	2
25	SS7110910TP	SCREW 11/64-40 L= 8.5	4
26	21337407	SQUARE BLOCK	2
27	21337803	FEED ADJUSTING BASE SUPPORT	2
28	SS8150822TP	SCREW 15/64-28 L=8	2
29	21338306	FELT SUPPORT	1
30	SS5090610SP	SCREW 9/64-40 L=6	2
31	21337902	ECCENTRIC PIN	1
32	SS709010TP	SCREW 9/64-40 L= 8.5	2
33	21337308	FEED ADJUSTING ROD	1
34	SD0800402TP	HINGE SCREW D= 8 H= 4	1
35	21337605	SPRING	1
36	21338009	SPRING HOOK	1
37	SS7111410TP	SCREW 11/64-40 L=16	2
38	21337209	FEED ADJUSTING A	1
39	B1610512000	FEED DRIVING SLIDE BLOCK	1
40	SM6061802TP	SCREW M6 L=18	1
41	21336805A	FEED DIAL A	1
42	010562	SPRING	1
43	SS6121860SP	SCREW 3/16-28 L=18	1
44	11009909	FEED REGULATOR SCREW	1
45	RO092270200	RUBBER RING	1
46	010563	FEED REGULATOR PIN	1
47	22912109	FEED REGULATOR PIN SPRING	1
48	21336656	FEED LINK ASM.	1
49	21336607	FEED LINK	(1)
50	B1418761000	CONNECTING FORKED LINK PIN	1

H7. FEED MECHANISM (2/2)

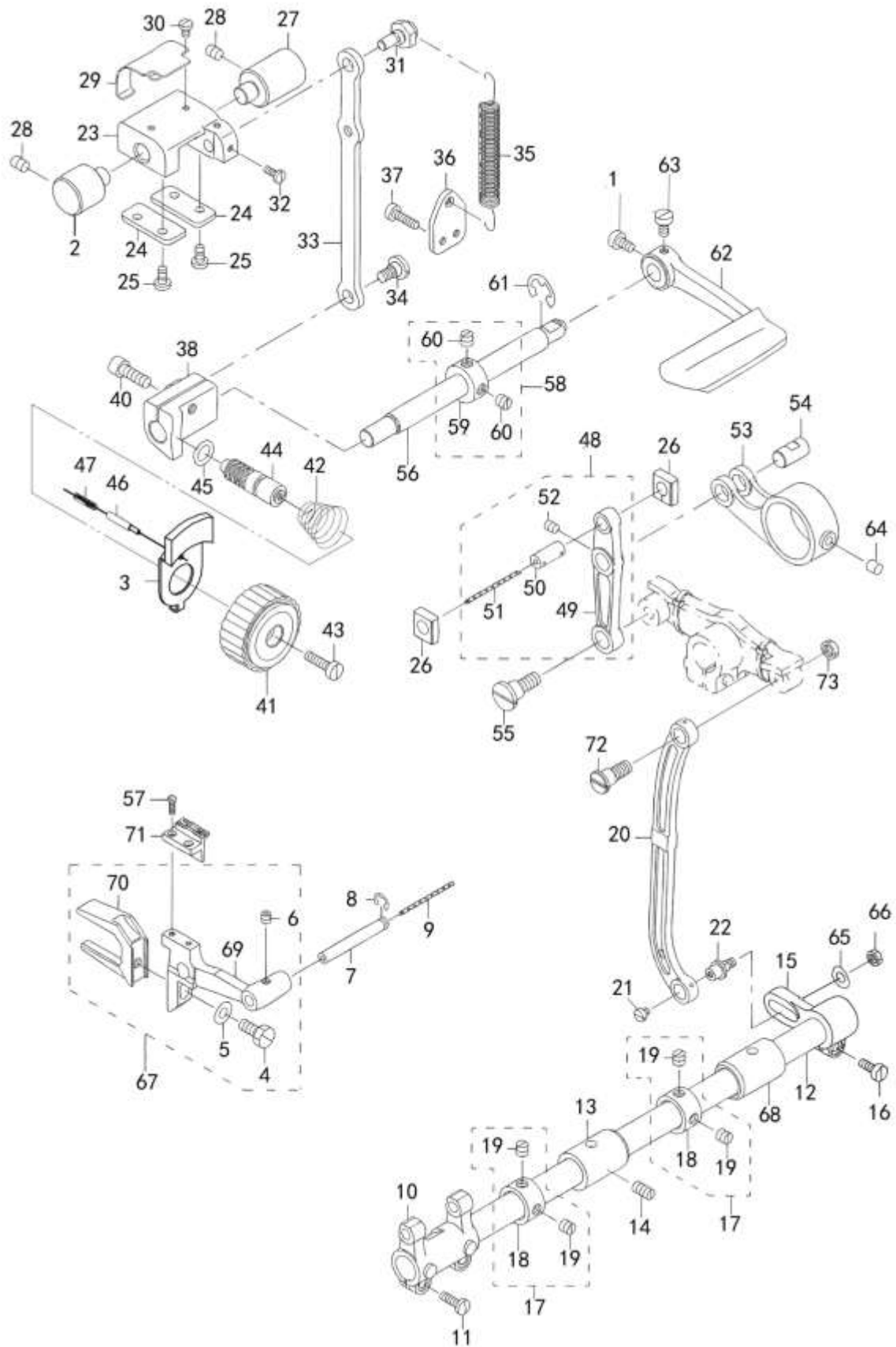

H7. FEED MECHANISM (2/2)			
Ref. No	Part No.	Part Name	Qty
51	CQ202000000	OIL WICK	0.04
52	SM8050502TP	SCREW M5X6	1
53	21336706	FEED ROD A	1
54	21338207	FEED LINK PIN	1
55	SD1000801SH	HINGE SCREW D=10 H=8	1
56	21336300	BACKWARD FEED LEVER SHAFT	1
57	SS6580752TP	SCREW 1/8-40 L=7	2
58	CS1201010SH	THRUST COLLAR ASM. D=12 W=10	1
59	CS1201011SH	THRUST COLLAR D=12 W=10	(1)
60	SS8660610TP	SS8660610TP SCREW 1/4-40 L=6	(2)
61	RE0900000K0	E-RING 9	1
62	21388004	REVERSE FEED CONTROL LEVER	1
63	SS6120930TP	SCREW 3/16-28 L=9	2
64	22814909	FELT	1
65	WP0621016SH	WASHER	1
66	010932	NUT 1/4-40	1
67	21364252	FEED BASE ASM.	1
68	020568	FEED SHAFT METAL	1
69	21336003	FEED BASE	1
70	10107902	FEED BAR FORK	1
71	B1613563E00D	FEED	1
72	SD0900701TP	SCREW	1
73	NS6680320SP	NUT 9/32 -28	1

H8. HOOK SHAFT & UPPER FEED MECHANISM

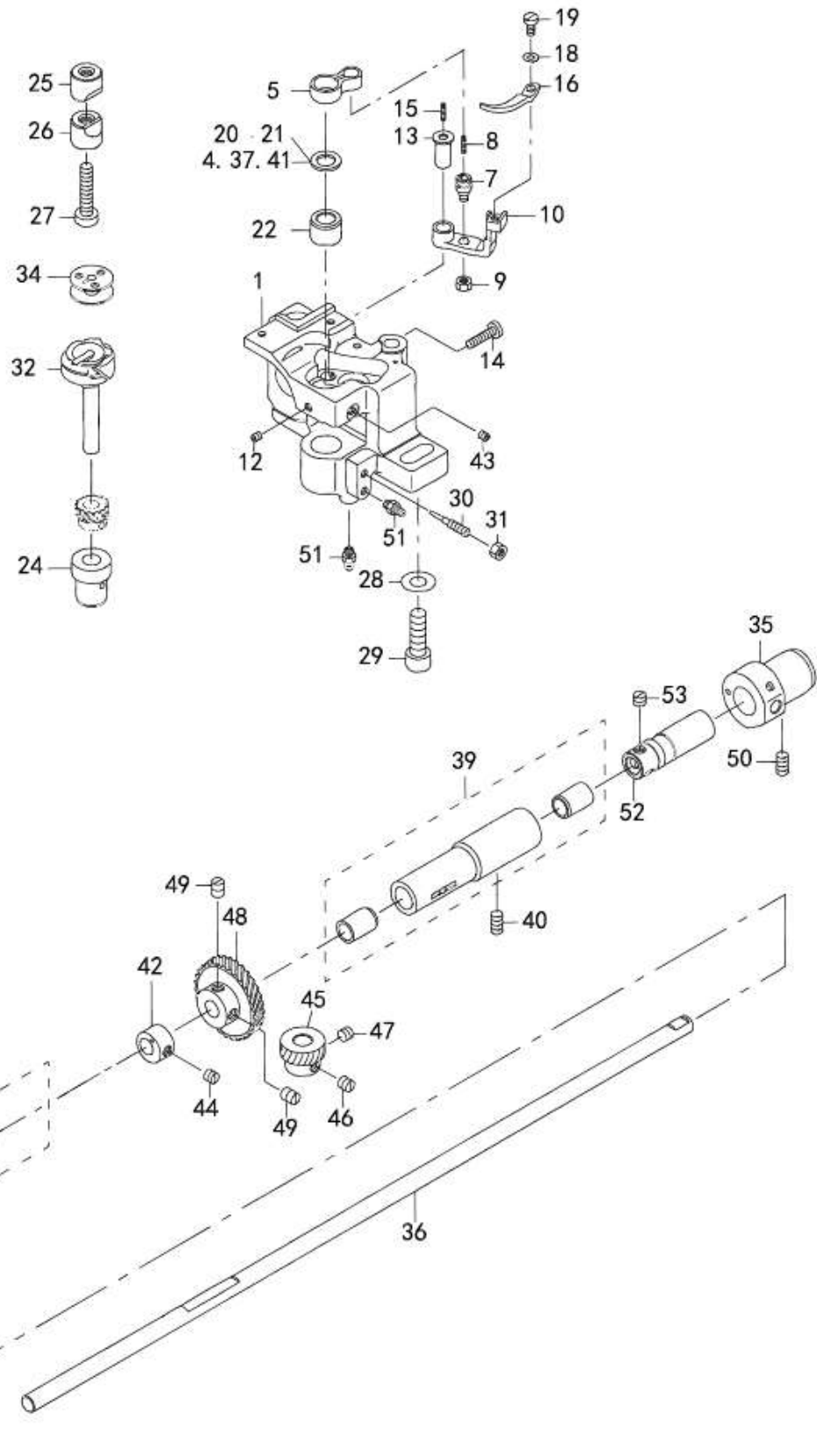

H8. HOOK SHAFT & UPPER FEED MECHANISM			
Ref. No	Part No.	Part Name	Qty
1	21390000	HOOK SHAFT BASE (RIGHT)	1
2	B1802563000A	BUSHING ASM. FRONT	1
4	10112506	THRUST WASHER 0.7	1
5	21334909	INNER HOOK GUIDE LINK	1
7	B1821051000	CRANK SCREW STUD	1
8	CQ202000000	OIL WICK	0.02
9	NS6110420SP	NUT 11/64-40	1
10	21335500	GUIDE ARM (FOR THREAD CUTTING)	1
12	SS8110422TP	SCREW 11/64-40 L=4	2
13	B1823051000	OPENING LEVER CRANK PIN	1
14	SS7111810TP	SCREW 11/64-40 L=18	1
15	CQ202000000	OIL WICK	0.02
16	21335807	INNER HOOK GUIDE	1
18	WP0371016SD	WASHER 3.7X8X1	1
19	SS6090810SP	SCREW 9/64-40 L= 7.5	1
20	10111102	THRUST WASHER 0.9	1
21	10112704	THRUST WASHER 1.2	(1)
22	21378401	HOOK SHAFT UPPER METAL	1
24	21334701	HOOK SHAFT LOWER METAL	1
25	10109908	SADDLE INSTALLING BLOCK UPPER	1
26	10112407	SADDLE INSTALLING BLOCK LOWER	1
27	SS6153040SP	SCREW 15/64-28 L=30	1
28	WP0850002SP	WASHER 8.5X18X1.6	1
29	SM6082502TP	SCREW M8 L=25	1
30	B1834512000A	OIL ADJUSTING SCREW	1
31	NS6110420SP	NUT 11/64-40	2
32	SC1510NI1	THREAD TRIMMER HOOK ASM.	1
34	21334800	ALUMINUM BOBBIN WITH KNURL	1
35	22611701	PLUNGER BUSHING B	1
36	020666	LOWER SHAFT	1
37	10111003	THRUST WASHER 1.1	1
38	SS8151150TP	SCREW 15/64-28 L=10.5	1
39	B18035150A0	BUSHING ASM. INTERMEDIATE	1
40	SS8151150TP	SCREW 15/64-28 L=10.5	1
41	10109700	THRUST WASHER 1.5	1
42	22609804	FEED DRIVING CAM	1
43	SS8110422TP	SCREW 11/64-40 L=4	1
44	SS8660530TP	SCREW 1/4-40 L= 4.5	1
45	B1817051000	HOOK DRIVING SHAFT GEAR SMALL	1
46	SS8660670SP	SCREW 1/4-40 L= 6.1	1
47	SS8660530TP	SCREW 1/4-40 L= 4.5	1
48	B1816051000	HOOK DRIVING SHAFT GEAR LARGE	1
49	SS8660810TP	SCREW 1/4-40 L=8	2
50	SS8151150SP	SCREW 15/64-28 L=10.5	1
51	SQ1110401MZ	CONNECTING SCREW	2
52	22611909	OIL PUMP SHAFT	1
53	SS8660530TP	SCREW 1/4-40 L= 4.5	1

H9. THREAD CUTTING COMPONENTS

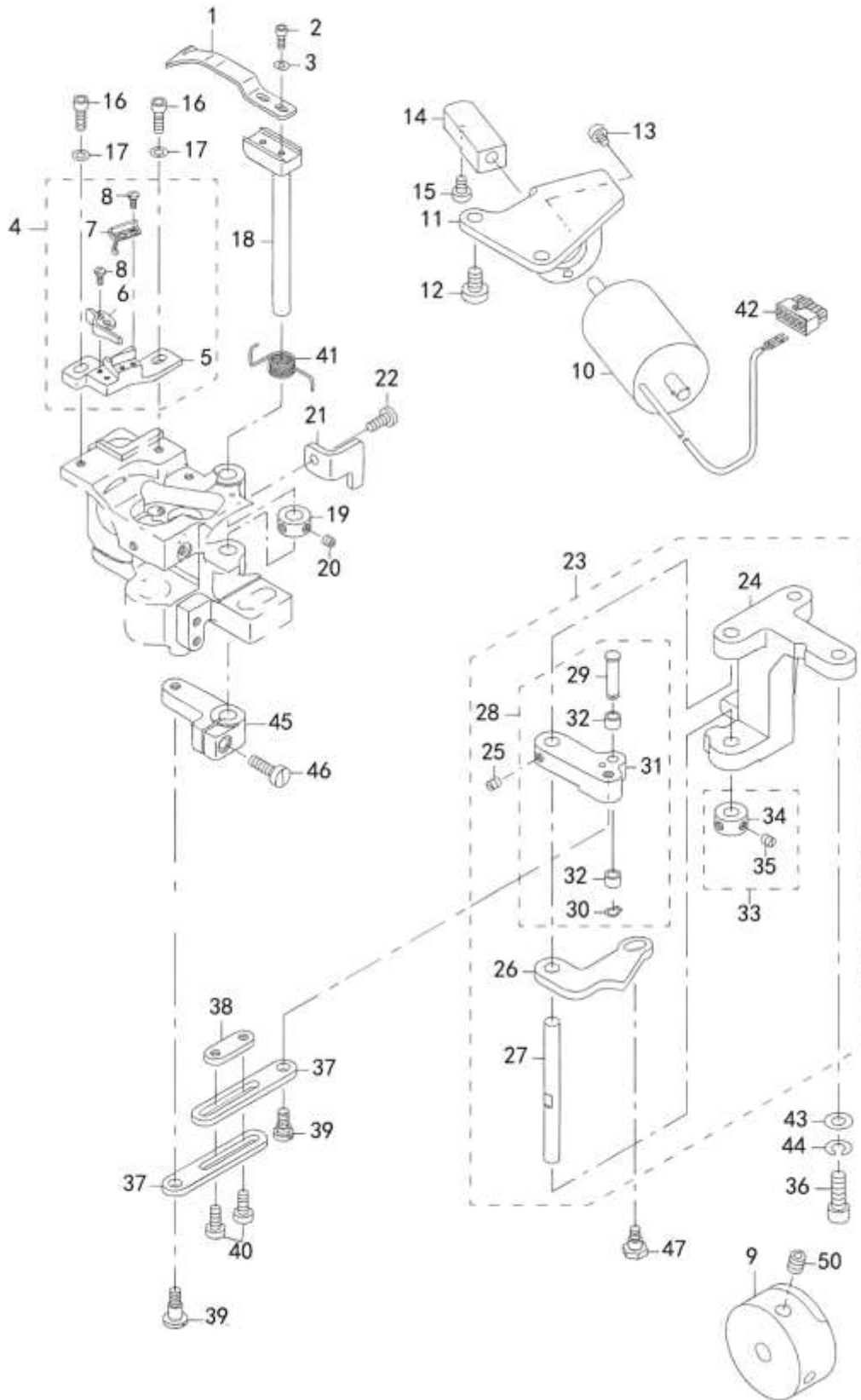

H9. THREAD CUTTING COMPONENTS			
Ref. No	Part No.	Part Name	Qty
1	21389200	MOVING KNIFE	1
2	SM6030802TP	SCREW M3X0.5 L=8	2
3	PD3	WASHER M3	2
4	21389556	FIXED KNIFE BASE (RIGHT) ASM.	1
5	21389507	FIXED KNIFE BASE (RIGHT)	1
6	21389309	FIXED KNIFE	1
7	21389408	CLAMP SPRING	1
8	SS7060610SP	SCREW 3/32-56 L= 5.5	4
9	21389911	THREAD TRIMMER CAM	1
10	21355102	THREAD CUTTING SOLENOID	1
11	21354600	SOLENOID FITTING PLATE	1
12	SS6151040SP	SCREW 15/64-28 L=10	2
13	SM6040802TP	SCREW M4X0.7 L=8	2
14	21354709	SOLENOID CONNECTING PLATE	1
15	SS6110710TP	SCREW 11/64-40 L= 6.5	2
16	SM6041202TP	SCREW M4X0.7 L=12	2
17	WP0430800SC	WASHER M4	2
18	21354907	MOVING KNIFE SHAFT	1
19	CS0790731SH	THRUST COLLAR	1
20	SS8110422TP	SCREW 11/64-40 L=4	2
21	21354501	THREAD CUTTING STOPPER (RIGHT)	1
22	SS7111120SP	SCREW 11/64-40 L=10.5	1
23	21353750	VERTICAL FITTING BASIS ASM.	1
24	21353701	VERTICAL FITTING BASIS	1
25	SS8110510SP	SCREW 11/64-40 L=5	2
26	21354006	THREAD CUTTING DRIVING PLATE	1
27	10116804	SHAFT	1
28	21353859	THREAD CUTTING ROLLER ARM	1
29	21353909	CAM ROLLER SHAFT	1
30	D2430555B00	SNAP RING	1
31	21353800	THREAD CUTTING ROLLER ARM	1
32	D2427555B00B	CAM ROLLER	2
33	CS070081BSH	THRUST COLLAR ASM. D=7 W=8	1
34	CS0700811SH	THRUST COLLAR D=7 W=8	1
35	SS8110510SP	SCREW 11/64-40 L=5	2
36	SS6151812TP	SCREW 15/64-28 L=18	2
37	21354105	CONNECTING PLATE	2
38	21354204	STOPPING PLATE	1
39	SD0640325SP	HINGE SCREW	2
40	SS7111120SP	SCREW 11/64-40 L=11	2
41	21390208	MAINTENANCE SPRING	2
42	K034610160	HOUSING 12P	1
43	WP0621016SD	WASHER 6.2X13X1	2
44	THQ6	SPRING WASHER	2
45	21389705	ROCKING ARM (RIGHT)	1
46	SS6121610TP	SCREW 3/16-28 L=15.5	1
47	SD0640482SP	HINGE SCREW D= 6.35 H= 4.8	1
48	SS6121610TP	SCREW 3/16-28 L=15.5	1
49	SD0640451TP	HINGE SCREW D=6.35 H=4.5	1
50	SS8660612TP	SCREW 1/4-40 L=6	2

H10. THREAD TENSION COMPONENTS

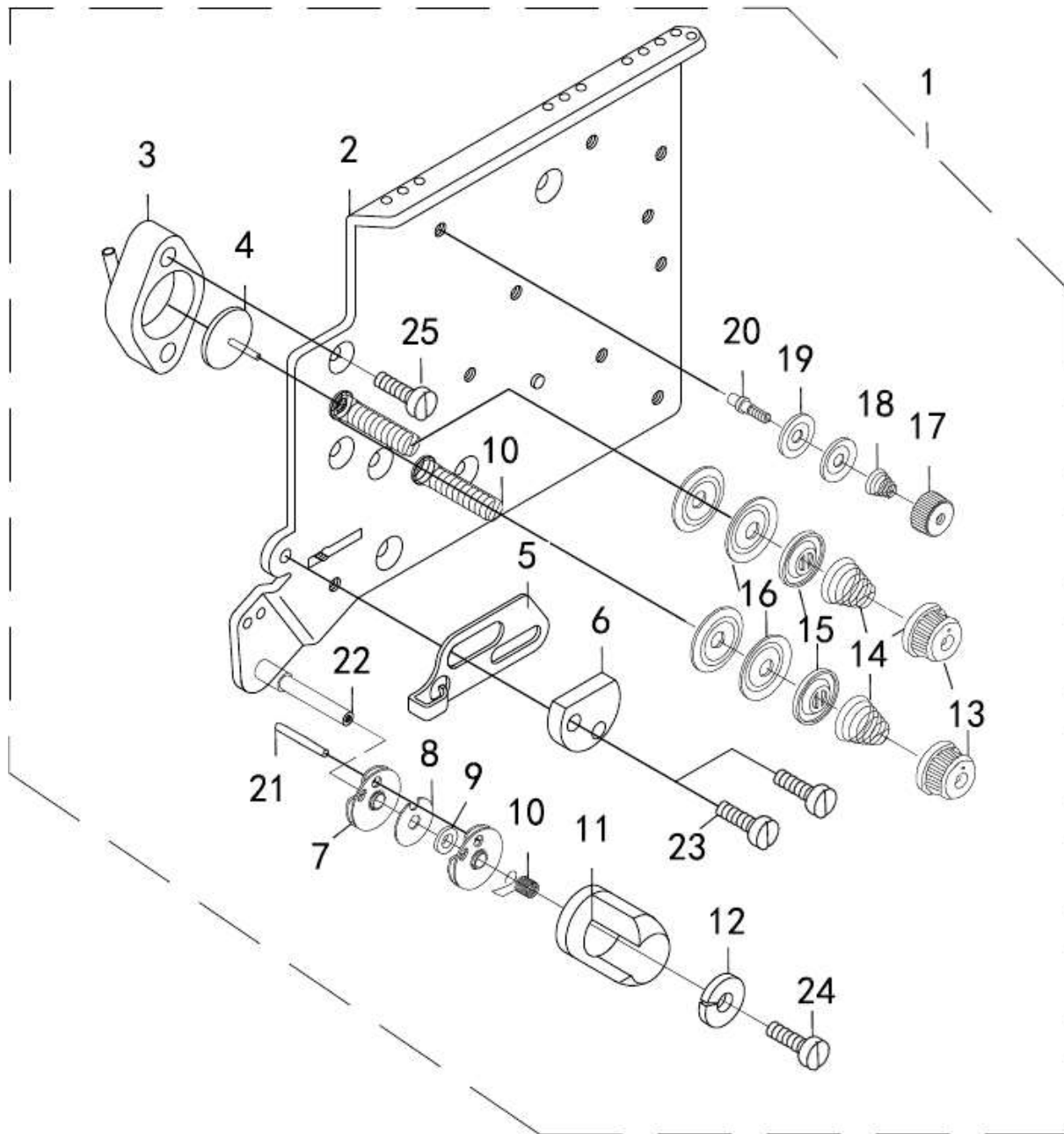

H10. THREAD TENSION COMPONENTS			
Ref. No	Part No.	Part Name	Qty
1	020841	THREAD TENSION ASM.	1
2	020841A	THREAD POST BASE COMPL.	1
3	020841B	CYLINDER BLOCK	2
4	020841C	CYLINDER THIMBLE	2
5	020841D	PASSING PLATE	1
6	020841E	PASSING PLATE	1
7	020841F	TAKE-UP SPRING GUIDE DISC ASM	2
8	020841G	PAD	1
9	020841H	PAD	1
10	020841I	TORSION SPRING	2
11	020841J	TORSION SPRING BRACKET	1
12	020841K	PAD	1
13	020841L	THREAD TENSION NUT	2
14	020841M	TENSION SPRING NO.1	2
15	020841N	BOBBIN WINDER TENSION DISC	2
16	020841O	BOBBIN WINDER TENSION DISC	4
17	020841P	TENSION NUT	2
18	020841Q	TENSION SPRING	2
19	020841R	TENSION DISC	2
20	020841S	THREAD TENSION POST B	2
21	020841T	PIN	1
22	020841U	AXIS	1
23	LS4C10	SCREW STUD	2
24	LS4C8	SCREW STUD	1
25	LS4N6	SCREW STUD	4

H11. LOVER THREAD WINDER MECHANISM COMPONENTS

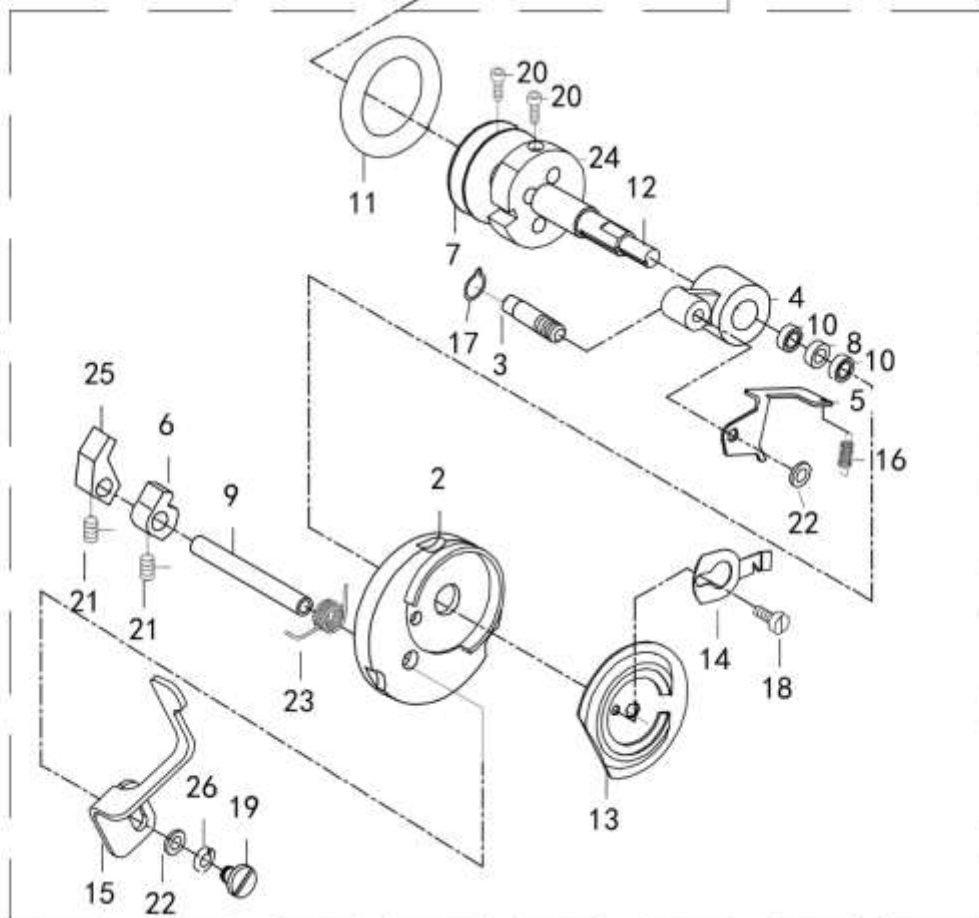
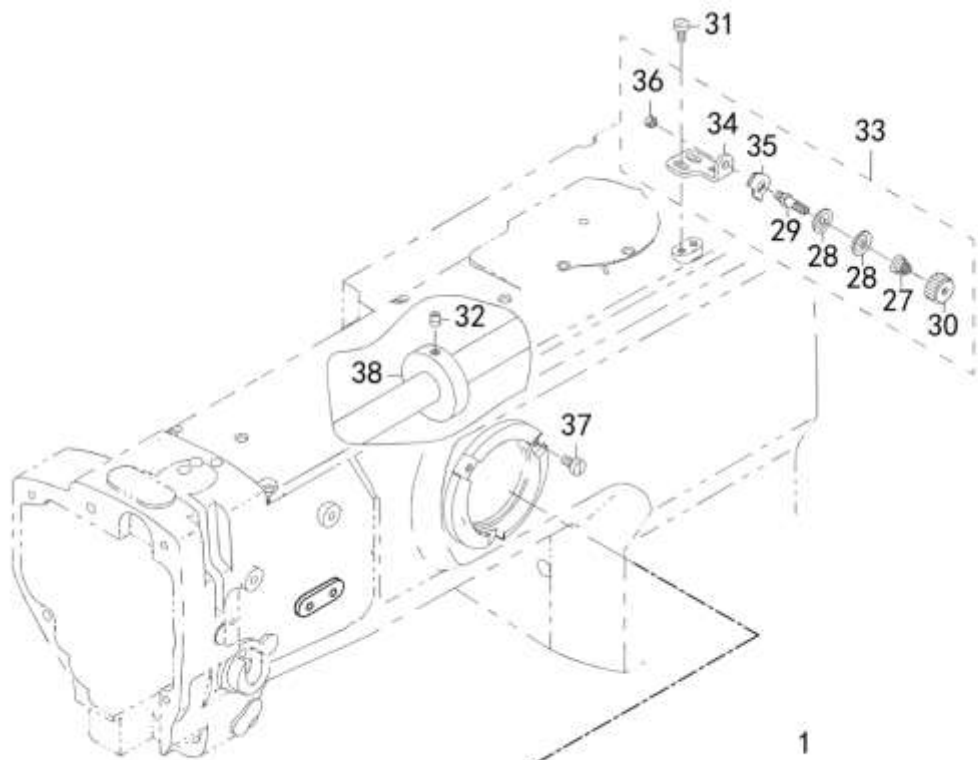

H11. LOWER THREAD WINDER MECHANISM COMPONENT			
Ref. No	Part No.	Part Name	Qty
1	40126355	BOBBIN DEVICE ASM.	1
2	26260109	BOBBIN FITTING BASIS COMPL.	1
3	26260307	ADJUSTING PLATE BEARING	1
4	26260406	CONNECTING ROD	1
5	40126594	ADJUSTING PLATE	1
6	26260505	STOP MOVING CARD	1
7	40125851	WHEEL SHAPE	1
8	26260802	RING	2
9	26261008	BEARING	1
10	40126354	BEARING SHAFT	1
11	26261503	FRICTION RUBBER CIRCLE	1
12	40126550	CENTER BEARING	1
13	40125927	RUBBER MAT	1
14	40126311	THREAD TRIMMER	1
15	40151791	HANDLE	1
16	13718507	SPRING	1
17	RC0560711KP	RING	1
18	SM0030601SC	SCREW 3*0.5 L=8	3
19	SM6040860TP	SCREW4*8	1
20	SM6031202TP	SCREW	2
21	SM8050502TP	SCREW	1
22	WP0450801SP	FLAT MAT	2
23	40126549	SPRING	1
24	40125928	POSITIONER	1
25	40125844	LIMITED CARD	1
26	WS0451040KP	SPRING WASHER	1
27	NS6110310SP	TENSION SPRING NO.1	1
28	D3168555H0B	BOBBIN WINDER TENSION DISC	2
29	B3214047000	THREAD TENSION POST	1
30	21378708	THREAD TENSION NUT	1
31	11072402	SCREW	2
32	SM8050602TP	SCREW M5 L=6	2
33	21355755	LOWER THREAD GUIDE ASM.	1
34	21355706	FITTING BASE	1
35	D3162555B00	THREAD GUIDE	1
36	NS6110310SP	NUT 11/64-40	1
37	SS6110810TP	SCREW 11/64-40 L=8	3
38	10704807	BOBBIN FRICTION WHEEL	1

H12. LUBRICATION COMPONENTS (1/2)

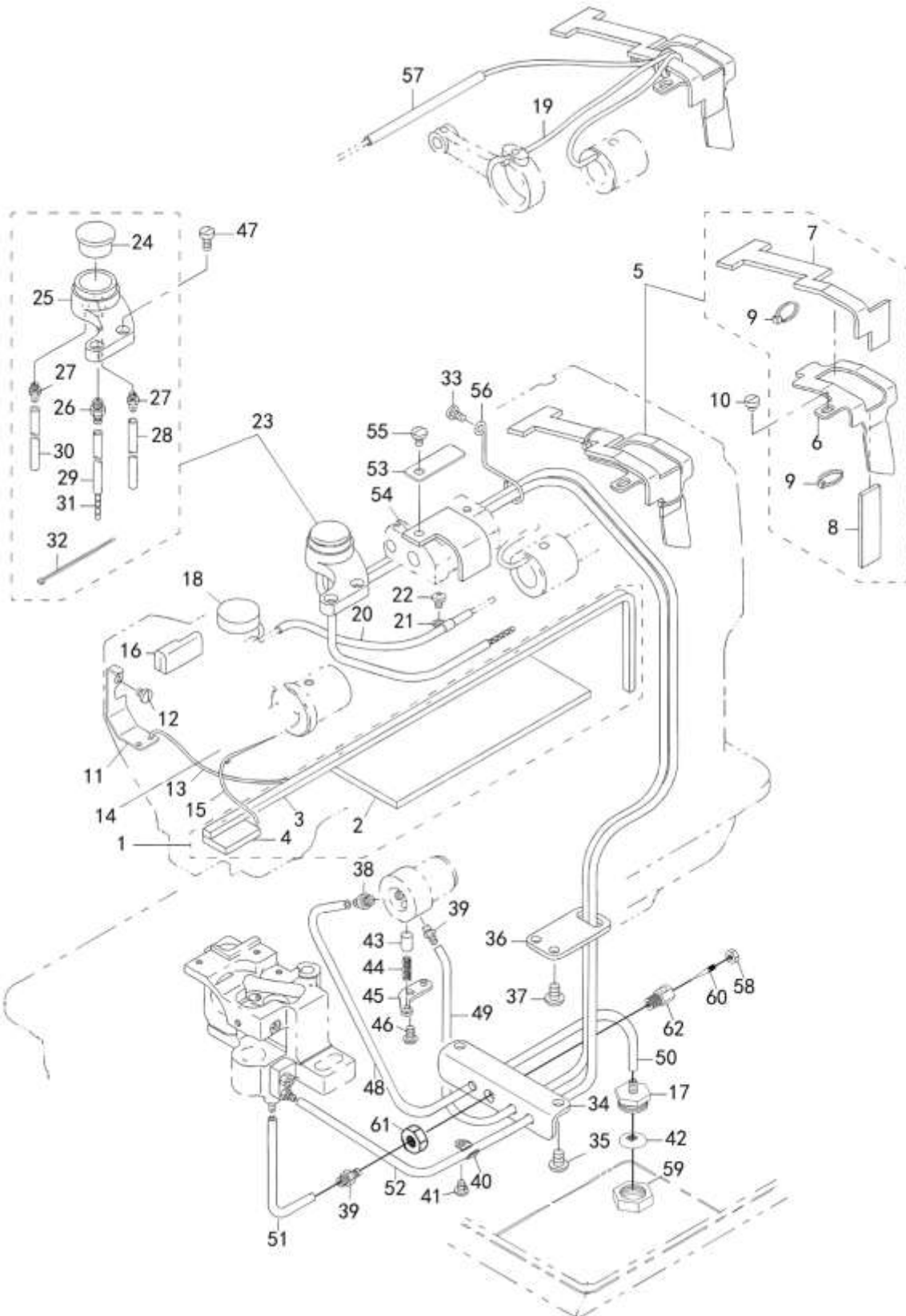

H12. LUBRICATION COMPONENTS (1/2)			
Ref. No	Part No.	Part Name	Qty
1	21345756	ARM ONCE THROUGH OIL FELT ASM.	1
2	21345707	ARM ONCE THROUGH FELT A	1
3	21345806	FELT B	1
4	21345905	FACE ONCE THROUGH FELT	1
5	21346358	FELT SUPPORT ASM.	1
6	21346309	FELT	1
7	21346507	FEED CHANGE FELT	1
8	21346408	FELT	1
9	EA9500B0000	CLIP CV-70S	2
10	SS7110710SP	SCREW 11/64-40 L=4.3	1
11	21340708	UPPER FEED OIL BAR PLATE	1
12	SS7110710SP	SCREW 11/64-40 L=5	1
13	CQ202000000	OIL WICK	0.2
14	21347000	TAKE-UP OIL PLATE	1
15	CQ202000000	OIL WICK	0.25
16	21347208	TAKE-UP LUBRICATION FELT	1
17	021363	OIL FILTER HEAD	1
18	21346002	FELT	1
19	CQ202000000	OIL WICK	0.2
20	BT0600402EA	OIL TUBE	0.12
21	B3538112000	OIL RETURN TUBE HOLDER	1
22	SS4110615SP	SCREW 11/64-40 L=6	1
23	40051503	ARM OIL TANK ASM.	1
24	B3520586000	OIL SIGHT WINDOW	1
25	21345608	ARM OIL TANK	1
26	SQ1110401MZ	CONNECTING SCREW	1
27	SQ1150451MZ	CONNECTING SCREW	2
28	23630007	TUBE	0.5
29	23630007	TUBE	0.2
30	23630007	TUBE	0.6
31	CQ202000000	OIL WICK	0.7
32	EA9500B0100	CABLE BAND	3
33	SS7110830SP	SCREW 11/64-40 L= 7.5	1
34	21345103	LUBRICATION BRACKET	1
35	SS4150915SP	SCREW 15/64-28 L=9	2
36	21345202	OIL PIPE STAY	1
37	SS4150915SP	SCREW 15/64-28 L=9	2
38	40064409	CONNECTION SCREW ASM.	1
39	SQ1110401MZ	CONNECTING SCREW	1
40	B3538112000	OIL RETURN TUBE HOLDER	1

H13. LUBRICATION COMPONENTS (2/2)

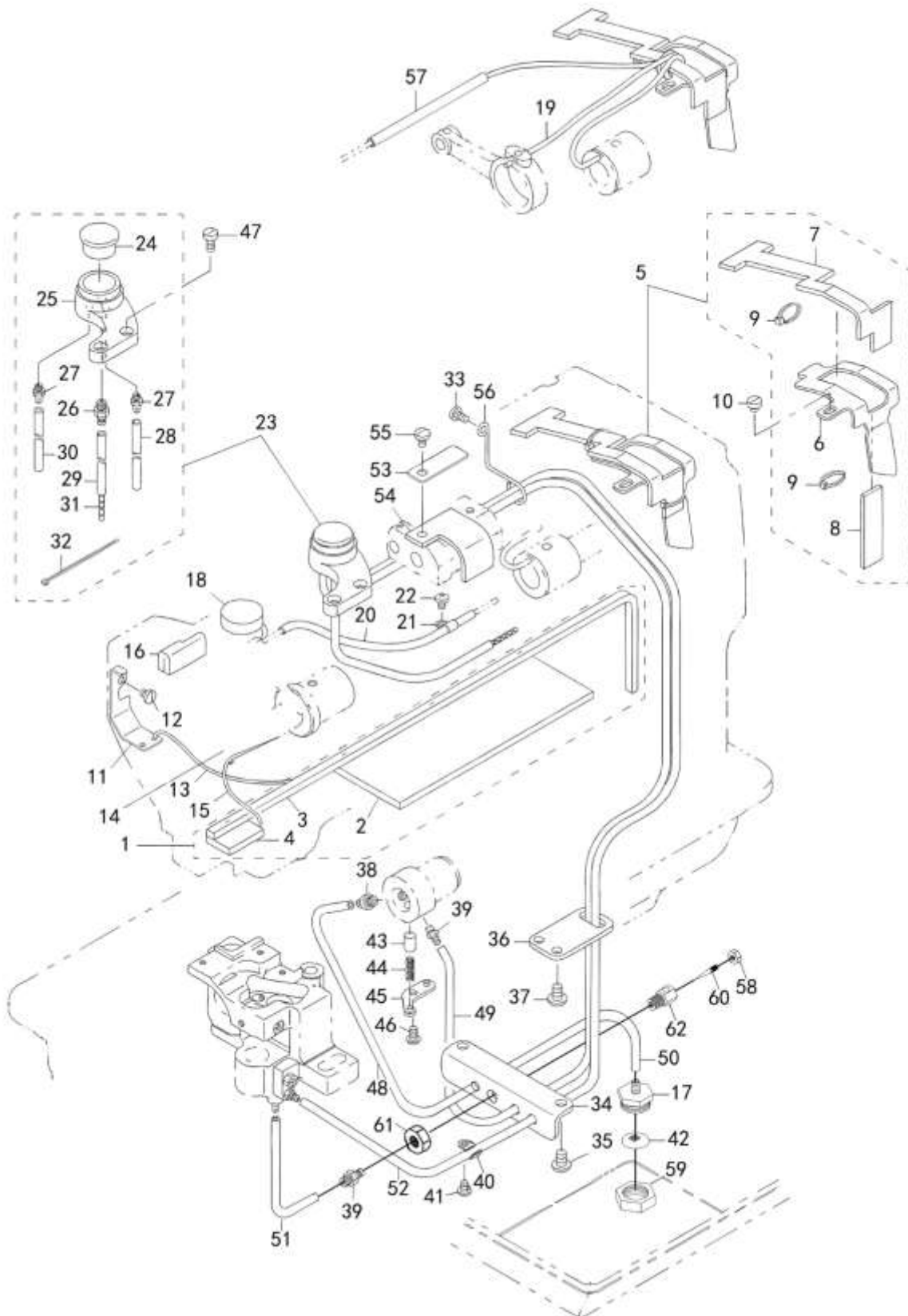

H13. LUBRICATION COMPONENTS (2/2)			
Ref. No	Part No.	Part Name	Qty
41	SS4110615SP	SCREW 11/64-40 L=6	1
42	021365	FILTER	1
43	B3534155000	PLUNGER	1
44	B1214038000	PLUNGER SPRING	1
45	B3524552000	PLUNGER THRUST PLATE	1
46	SS4110815SP	SCREW 11/64-40 L=8	1
47	SS6111010SP	SCREW 11/64-40 L= 9.5	2
48	23630007	TUBE	0.36
49	23630007	TUBE	0.5
50	23630007	TUBE	0.22
51	23630007	TUBE	0.1
52	23630007	TUBE	0.5
53	21338306	LUBRICATION FELT PRESSER	1
54	SS5090610SP	MUTUAL VERTICAL CHANGE FELT	1
55	SS5090610SP	SCREW 3/16-28 L= 7.0	1
56	21346606	PIPE SUPPORT	1
57	23630007	TUBE	0.22
58	010624	NUT 11/64-40	1
59	021364	COVER	1
60	010623	SCREW	1
61	LM8	NUT 8	1
62	021360	THROTTLE SLEEVE	1

H14. AUTOMATIC PRESSER LIFTING MECHANISM

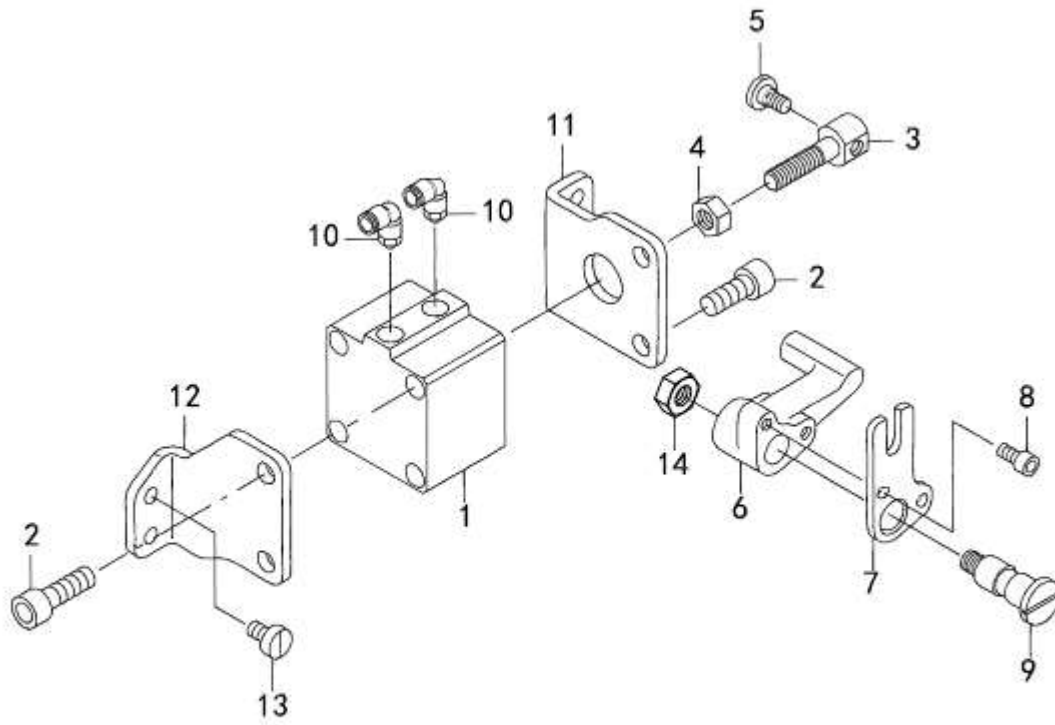

H14. AUTOMATIC PRESSER LIFTING MECHANISM			
Ref. No	Part No.	Part Name	Qty
1	ACQ40*15	AIR CYLINDER	1
2	LS8A20	SCREW M8 L=20	4
3	21356506	CYLINDER CONNECTING SCREW	1
4	NM6080001SE	NUT M8	1
5	SD0720331SP	HINGE SCREW D= 7.24 H= 3.3	1
6	21356605	LEVER A	1
7	21356803	LEVER B	1
8	LS5A10	SCREW M5X0.8 L=10	2
9	21356704A	SHAFT	1
10	SPL4-01	ELBOW	2
11	21356308	CYLINDER STAY(FRONT)	1
12	21356407	CYLINDER STAY(REAR)	1
13	SS6151040SP	SCREW 15/64-28 L=10	4
14	21356704B	NUT 5/16-24T	1

H15. THREAD STAND COMPONENTS

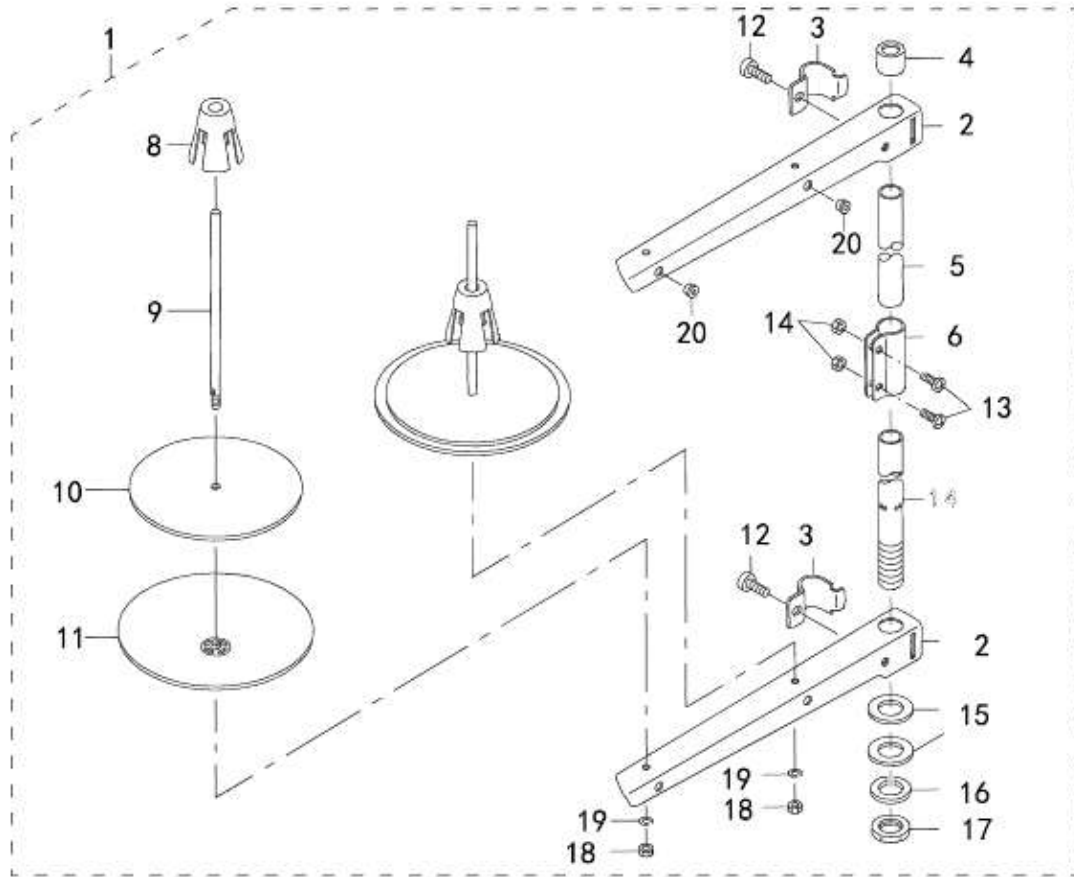

H15. THREAD STAND COMPONENTS			
Ref. No	Part No.	Part Name	Qty
1	22930358	THREAD STAND ASM.	1
2	22931109	SPOOL RETAINER	<2>
3	22931000	SPOOL PIN	<2>
4	22930903	SPOOL REST CUSHION	<2>
5	22930804	SPOOL REST	<2>
6	SM6061610SC	SCREW M6 L=16	<2>
7	22930705	THREAD GUIDE ARM JOINT	<2>
8	22931406	SPOOL REST ROD RUBBER CAP	<1>
9	22930507	SPOOL REST ARM	<2>
10	22931308	SPOOL REST ROD UPPER	<1>
11	22931307	SPOOL REST ROD JOINT	<1>
12	SM4051408SE	SCREW M5 L=14	<2>
13	NM6050001SE	NUT M5	<2>
14	22930309	SPOOL REST ROD LOWER	<1>
15	22931208	THREAD GUIDE	<2>
16	WS0510002KN	SPRING WASHER	<2>
17	NM6050001SE	NUT M5	<2>
18	NM6160511SE	NUT M16X1.5	<1>
19	WP1612616SE	WASHER 16X30X2.6	<2>
20	WS1643202KP	SPRING WASHER	<1>

H16. AUTOMATIC BACK-TACK COMPONENTS

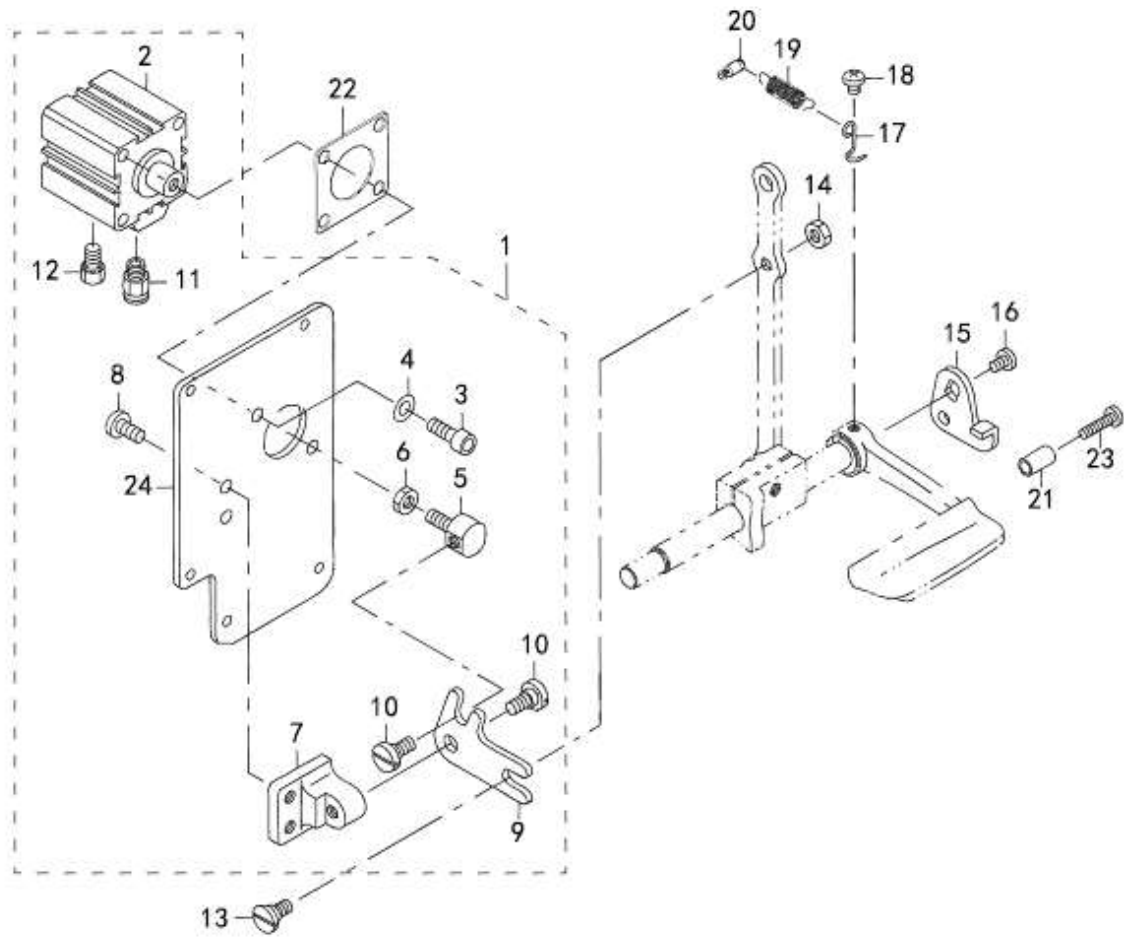

H16. AUTOMATIC BACK-TACK COMPONENTS			
Ref. No	Part No.	Part Name	Qty
1	21348958	WINDOW PLATE ASM.	1
2	SDA32*15	JIG CYLINDER	1
3	LS6A16	SCREW M6 L=16	2
4	PD6	WASHER 6	2
5	21348602	CYLINDER CONNECTING SCREW	1
6	LM6	NUT M6	1
7	21348503	FITTING BASE	1
8	SS7151210SP	SCREW 15/64-28 L=12	2
9	21348701	BACKWARD FEED LINK	1
10	SD0800352SP	HINGE SCREW D= 8 H= 3.5	2
11	SPC4-1	HALF UNION	1
12	PST01	MUFFLER	1
13	SD0800402TP	HINGE SCREW D= 8 H= 4	1
14	NS6150430SP	NUT 15/64-28	1
15	22656102	REVERSE FEED LINK (1)	1
16	SS7120760SP	SCREW 3/16-28 L= 7.0	1
17	22656003	SPRING SUSPENSION	1
18	SS4120615SP	SCREW 3/16-28 L=6	1
19	13515606	SPRING	1
20	10120004	SPRING SUSPENSION	1
21	11100500	REVERSE FEED LEVER STOPPER	1
22	21349105	CYLINDER PACKING	1
23	SS7111810SP	SCREW 11/64-40 L=18	1
24	21348909	WIDOW PLATE D	1

H17. DL-MECHANISM COMPONENTS

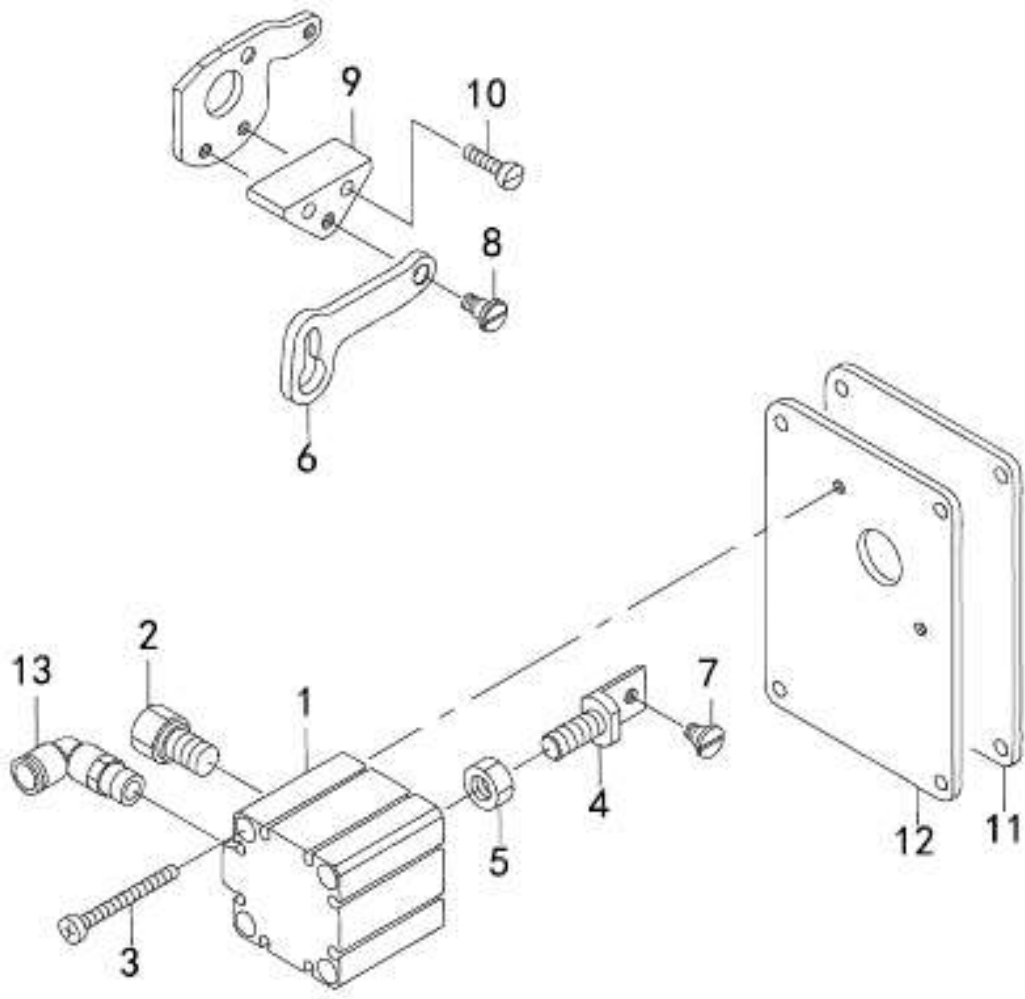

H17. DL-MECHANISM COMPONENTS			
Ref. No	Part No.	Part Name	Qty
1	SDA32*15	JIG CYLINDER	1
2	PST-01	MUFFLER	1
3	SM6044002TP	SCREW	2
4	21438403	CYLYNDER CONNECTING SCREW	1
5	LM8	NUT M8	1
6	21438502	MUTUAL VERTICAL LINK	1
7	SD0600403TP	HINGE SCREW	1
8	SD0600454TP	SHOULDER SCREW	1
9	21438601	MUTUAL VERTICAL LINK SPASER	1
10	SS6111610SP	SCREW 11/64-40 L=16	2
11	21437306	WINDOW PLATE E PACKING	1
12	21437207	WINDOW PLATE F	1
13	SPL4-1	ELBOW	1

H18. AIR MECHANISM COMPONENTS

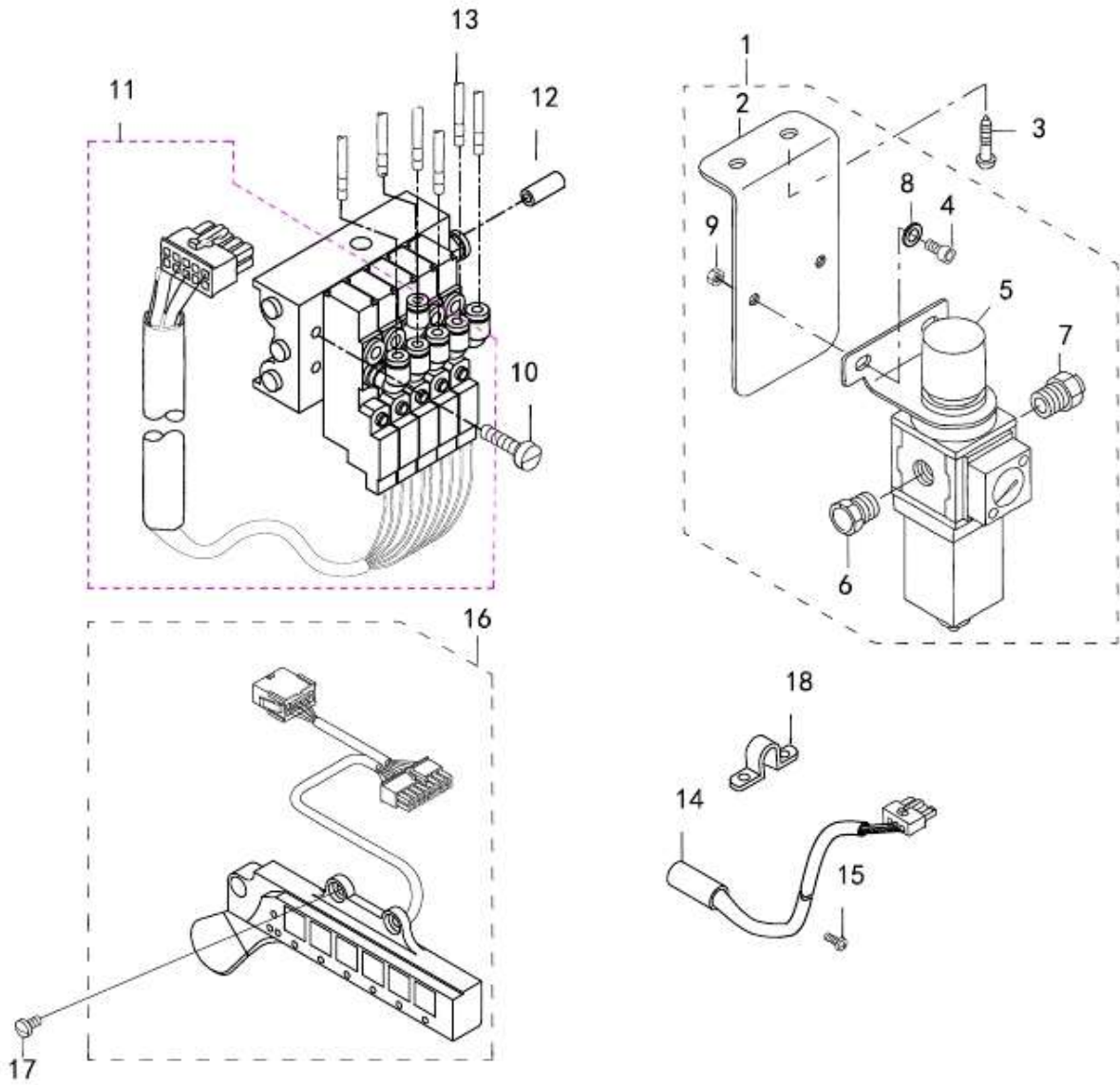

H18. AIR MECHANISM COMPONENTS			
Ref. No	Part No.	Part Name	Qty
1	021701	AIR APPARATUS (B) ASM.	1
2	021723	MOUNTING PANEL	1
3	021703	SCREW D=4.1 L=20	2
4	021704	SCREW M6 L=10	2
5	021705	FILTER REGULATOR	1
6	SPC8-01	NIPPLE	1
7	SPL6-01	NIPPLE	1
8	WP0621016SH	FLAT PAD	2
9	LM6	NUT	2
10	040151	SCREW	3
11	022238	ELECTROMAGNETIC VALVE ASM.	1
12	APU0604 L=500	TUBE Ø6	1
13	APU0425 L=500	TUBE Ø4	6
14	021658A	SAFETY SWITCH	1
15	SS4110815SP	SCREW	2
16	021654	5RANGE SWITCH ASM.	1
17	SS7110710SP	SCREW	3
18	021726	PIPE CLAMP	1